

GENERAC[®] | **MOBILE
PRODUCTS**

**DIESEL LIGHT TOWER
MLT3060KV • MLT3060MV • MLT3080KV**

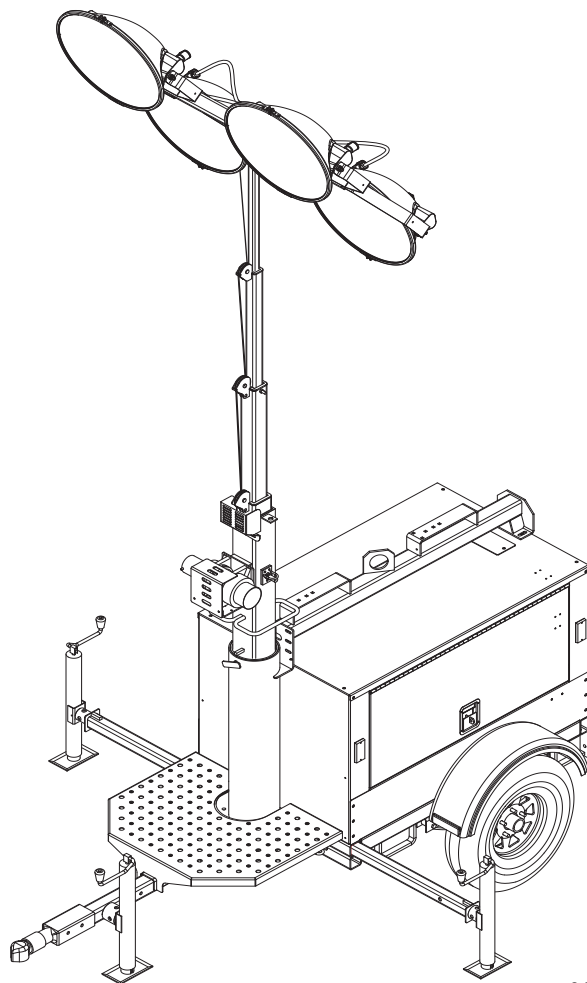

01218

PARTS MANUAL

⚠ WARNING

CALIFORNIA PROPOSITION 65 WARNING: Diesel engine exhaust and some of its constituents are known to the state of California to cause cancer, birth defects, and other reproductive harm.

⚠ WARNING

CALIFORNIA PROPOSITION 65 WARNING: This product contains or emits chemicals known to the state of California to cause cancer, birth defects, and other reproductive harm.

Introduction

This parts manual was prepared based on the information available at the time of publication and is subject to change without notice. Generac Mobile Products reserves the right to change parts at any time. To check whether a revised parts manual is available, contact Generac Mobile Products.

DO NOT MODIFY or use this equipment for any application other than which it was designed for. To keep your equipment fully operational, it is suggested you maintain a stock of commonly used maintenance or service parts. A recommended spare parts list can be found in the back of this manual. To order service parts, please go to www.generacmobile.com or call Generac Mobile Products.

▲ WARNING

Before operating or servicing this equipment, read and understand the Generac Operating Manual which was included with the unit when shipped from the factory.

Failure to do so increases the risk of injury to yourself or others.

GENERAC MOBILE PRODUCTS LLC

215 Power Drive • Berlin, WI 54923 U.S.A.

Phone: 920-361-4442

FAX: 920-361-4416

Toll Free: 1-800-926-9768

www.generacmobile.com

For technical or parts QUESTIONS, please contact the Generac Mobile Products Customer Support or Technical Support team at 1-800-926-9768.

Engine Make: _____

Engine Serial Number: _____

Engine Model Number: _____

Generator Make: _____

Generator Model Number: _____

Generator Serial Number: _____

Unit Model Number: _____

Unit Serial Number: _____

This Page Intentionally Left Blank

Table of Contents

Introduction	iii
Parts Manual Instructions	1
Unit Decals - Exterior	2
Unit Decals - Right Side Interior	3
Unit Decals - Left Side Interior	4
Mast, Junction Box and Lights to Unit	6
Light Assembly	8
Mast Junction Box Assembly - Hard Wired Lights	10
Mast Junction Box Assembly - Quick Disconnect Lights Option	12
Mast Assembly	14
Mast Assembly - Bottom Post	16
Roof and Doors to Unit	18
Front, Rear, and Side Panels to Unit	20
Mast Switch Box Assembly	22
Control Box to Unit	24
Control Box Assembly	26
Control Panel Assembly - MLT3060KV, MLT3060MV	28
Control Panel Assembly - MLT3080KV	30
Cooling System Assembly	32
Engine and Generator to Unit	34
Engine Assembly - Mitsubishi Left Side	36
Engine Assembly - Mitsubishi Right Side	38
Engine Assembly - Kubota Left Side	40
Engine Assembly - Kubota Right Side	42
Generator Assembly	44
Fuel Tank and Ballast Boxes to Unit	46
Trailer Assembly	48
Trailer - Jack and Hitch Options	50
Axle Assembly	52
Recommended Spare Parts List (1 of 2)	54
Recommended Spare Parts List (2 of 2)	55

This Page Intentionally Left Blank

Parts Manual Instructions

Product illustrations are only representations. Products supplied may vary from the illustrations in this parts manual. Parts not shown in the illustration are indicated by a double dash (--) in the item column.

Please be prepared to provide the following information when ordering replacement parts: model number, serial number (on unit serial tag), part number, purchase order number (if applicable), shipping address, shipping method.

Refer to the illustration below to locate the unit ID tag and Vehicle Identification Number (VIN) tag on the unit. Important information, such as the unit serial number, model number, VIN and tire loading information are found on these tags. Record the information from these tags so it is available if the tags are lost or damaged. When ordering parts or requesting assistance, you may be asked to provide this information.

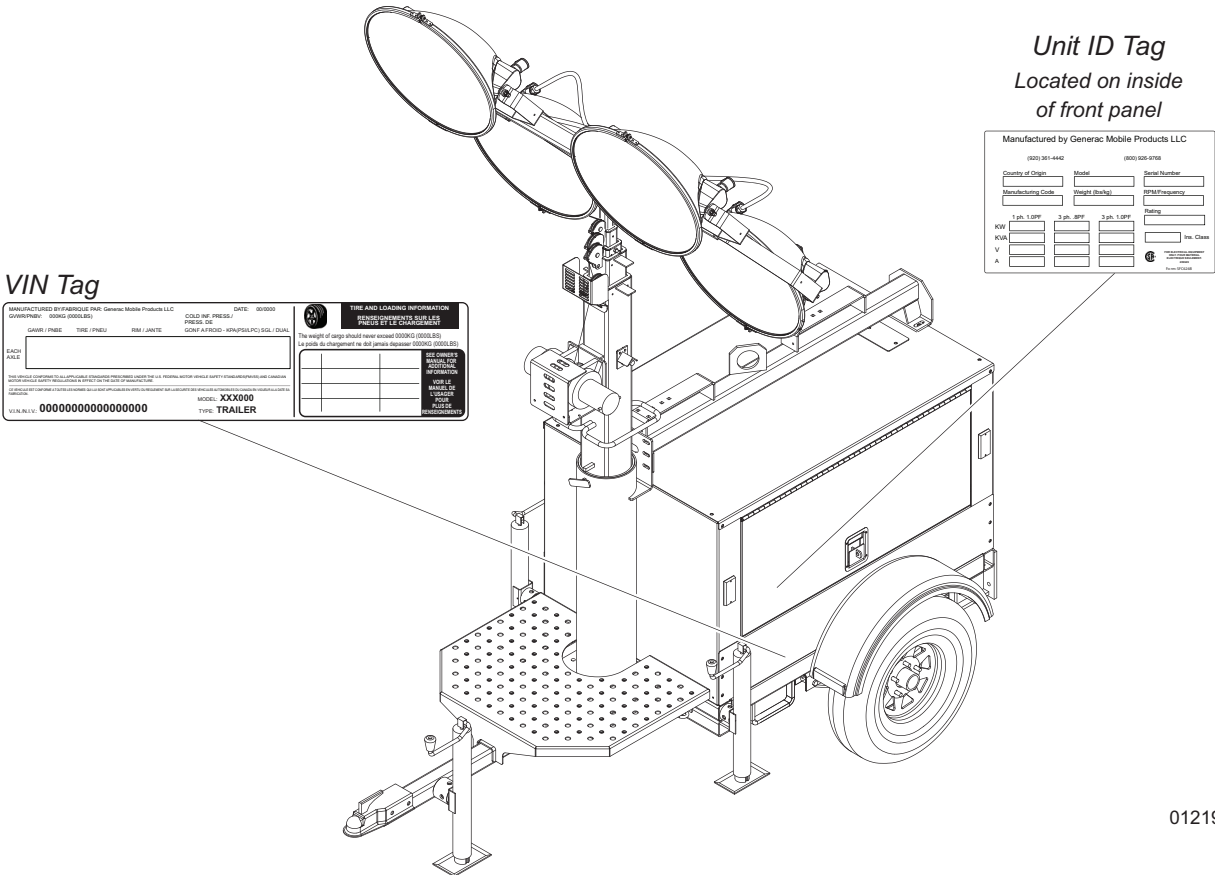

01219

UNIT DECALS - EXTERIOR

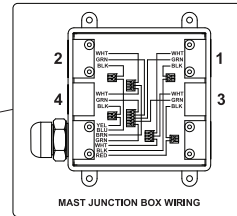
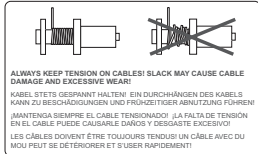

PN: 13614
 Decal, Mast Junction Box
 Located inside box

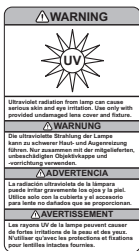

PN: 70164
 Decal, Do Not Remove Bolt

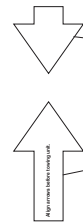
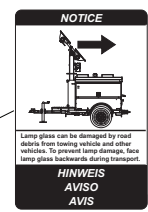

PN: 12142
 Decal, Ground
 Next to ground stud

TOWING INSTRUCTIONS	ABSCHLEPPANWEISUNGEN	INSTRUCCIONES PARA REMOLQUE	INSTRUZIONI DI RIMOVIAMENTO
1. Use approved towing equipment. 2. Do not tow the unit on its side. 3. Do not tow the unit on its front or back. 4. Do not tow the unit on its wheels. 5. Do not tow the unit on its lights. 6. Do not tow the unit on its mast.	1. Utilice el equipo de remolque aprobado. 2. No remolque la unidad sobre su lado. 3. No remolque la unidad sobre su frente o su trasera. 4. No remolque la unidad sobre sus ruedas. 5. No remolque la unidad sobre sus luces. 6. No remolque la unidad sobre su mástil.	1. Use approved towing equipment. 2. Do not tow the unit on its side. 3. Do not tow the unit on its front or back. 4. Do not tow the unit on its wheels. 5. Do not tow the unit on its lights. 6. Do not tow the unit on its mast.	1. Utilizzare l'attrezzatura di traino approvata. 2. Non trainare l'unità sul suo lato. 3. Non trainare l'unità sul suo fronte o sul retro. 4. Non trainare l'unità sulle ruote. 5. Non trainare l'unità sulle luci. 6. Non trainare l'unità sul suo mastice.

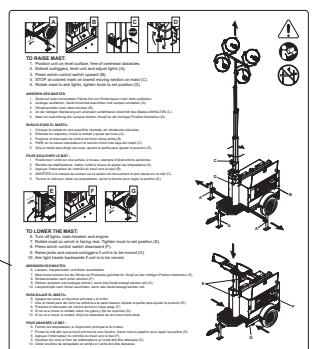

PN: 33323
 Decal, Mast Setup, Vertical

Note: All safety and operating decals are located on decal sheet 33953 unless otherwise noted.

UNIT DECALS - RIGHT SIDE INTERIOR

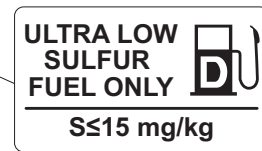

PN: 27433
Decal, Low Sulfur



01222

Note: All safety and operating decals are located on decal sheet 33953 unless otherwise noted.

UNIT DECALS - LEFT SIDE INTERIOR

ENGINE OPERATION / MOTORBETRIEB / FUNCIONAMIENTO DEL MOTOR / FONCTIONNEMENT DU MOTEUR:	
1 BEFORE STARTING THE ENGINE / VOR DEM STARTEN DES MOTORS / ANTES DE ENCENDER EL MOTOR / AVANT DE FAIRE DEMARRER LE MOTEUR: 1. CHECK FUEL LEVEL. / TROPPEL DES NIVEAU DE COMBUSTIBLE. / VERIFICALO EL NIVEL DE COMBUSTIBLE. / VERIFIEZ LE NIVEAU D'ESSENCE. 2. CHECK ENGINE OIL LEVEL. / MOTOREL NIVEAU OLIEF. / VERIFICALO EL NIVEL DE ACEITE DEL MOTOR. / VERIFIEZ LE NIVEAU D'HUILE DU MOTEUR. 3. CHECK COOLANT LEVEL. / KUHLEWASSER NIVEL. / VERIFICALO EL NIVEL DEL REFRIGERANTE. / VERIFIEZ LE NIVEAU DE LIQUIDE DE REFRIGERISSEMENT. 4. MAKE SURE MAIN CIRCUIT BREAKER IS OFF. / HAUPTSTROMSCHALTER SIND AUS. / ASEGURESE DE QUE EL CORTACIRCUITOS PRINCIPAL ESTE APAGADO. / ASSUREZ-VOUS QUE LE DISJONCTEUR OU CIRCUIT PRINCIPAL ESTE ENNEIGNE.	
2 ALL CIRCUIT BREAKERS OFF! / ALLE TRENNSCHALTER SIND AUSGESCHALTET! / TODOS LOS CORTACIRCUITOS ESTAN APAGADOS! / TOUS LES DISJONCTEURS DU CIRCUIT SONT DESACTIVES! 	
3 START ENGINE / MOTOR STARTEN / ENCIENDA EL MOTOR / FAIRE DEMARRER LE MOTEUR ACTIVE/ACTIVER LE MOTEUR CHANK ENGINE TO START RELEASE KEY 	
4 TURN CIRCUIT BREAKERS ON / TRENNSCHALTER EINSCHALTEN / ENCIENDA LOS CORTACIRCUITOS / ACTIVER LES DISJONCTEURS DU CIRCUIT 	
SHUT DOWN / AUSSCHALTEN / APAGUE / ÉTEINDRE	
5 ALL CIRCUIT BREAKERS OFF! / ALLE TRENNSCHALTER SIND AUSGESCHALTET! / TODOS LOS CORTACIRCUITOS ESTAN APAGADOS! / TOUS LES DISJONCTEURS DU CIRCUIT SONT DESACTIVES! 	
6 STOP ENGINE / MOTOR STOPPEN / DETENGA EL MOTOR / ÉTEINDRE LE MOTEUR 	

WARNING

Read and understand the supplied operator's manual before operating this machine. Failure to do so increases the risk of injury to yourself or others.

WARNING

Vor dem Betrieb dieser Maschine muss das Bedienhandbuch gelesen und verstanden worden sein. Ein Unterlassen erhöht das Risiko von Verletzungen und das eigene.

ADVERTENCIA

Lea y asegúrese de comprender el manual del operador proporcionado antes de operar esta máquina. De lo contrario, aumenta el riesgo de lesiones a usted y a otras personas.

AVERTISSEMENT

Lire et comprenez le manuel de l'utilisateur fourni avec l'appareil avant de l'utiliser. L'omission de la faire augmente le risque de blessure pour vous et pour les autres.

PN: 12142
Decal, Ground

PN: 33552
Decal, Mast Up/Down

Note: All safety and operating decals are located on decal sheet 33953 unless otherwise noted.

This Page Intentionally Left Blank

MAST, JUNCTION BOX AND LIGHTS TO UNIT

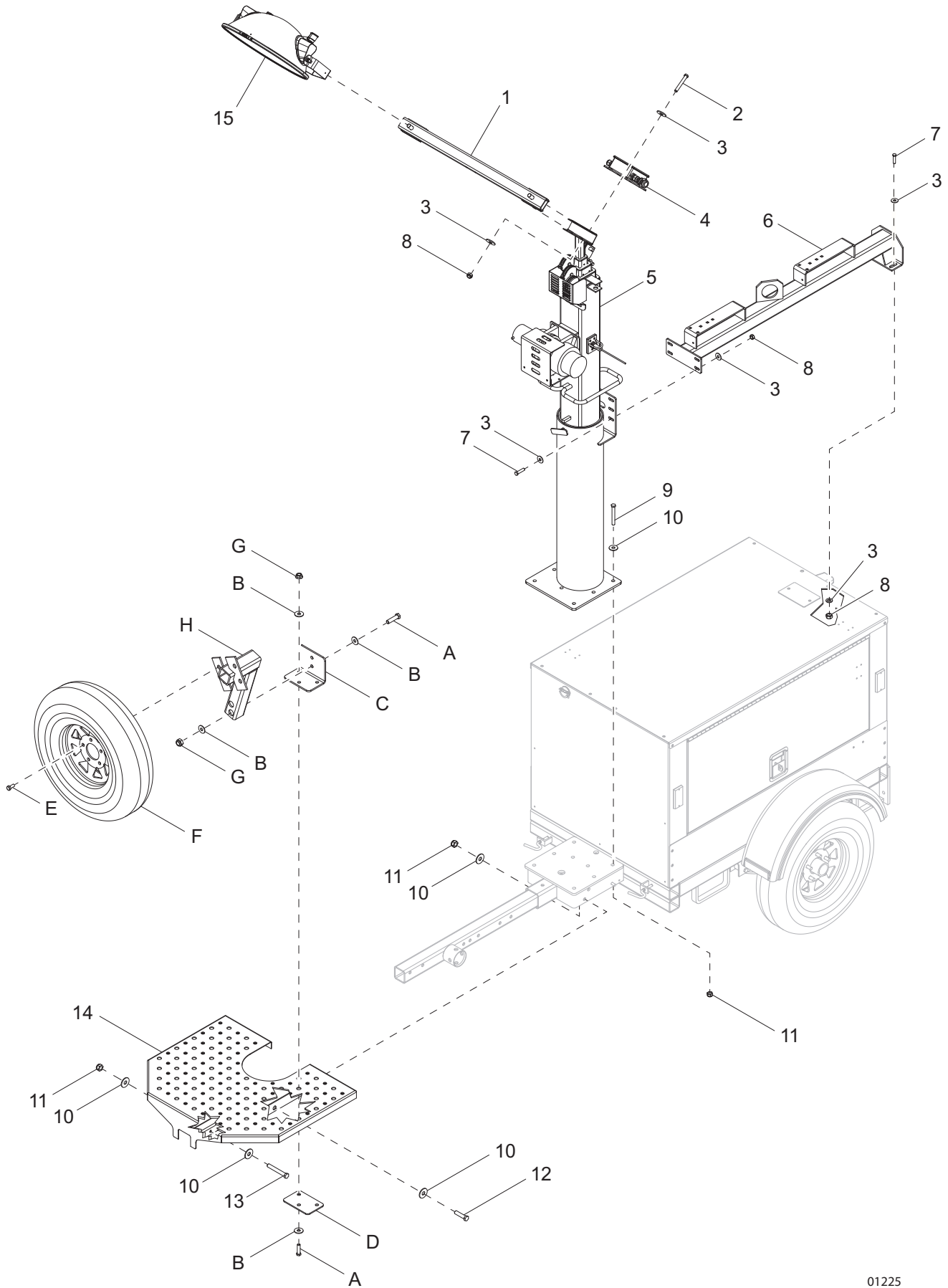

01225

MAST, JUNCTION BOX AND LIGHTS TO UNIT

Item	Part No.	Qty	Description	Notes
1	13527B	1	Weldment, mast crossbar	
2	60753	2	Screw, .375-16 x 3.50 std hex, G5	
3	60698	12	Washer, .375 flat .875/.040, SS	
4	Page 10	1	Assembly, mast junction box	
5	Page 14	1	Assembly, mast	
6	33041B	1	Weldment, lift support	
7	61036	4	Screw, .375-16 x 1.250 std hex, SS	
8	60358	6	Nut, .375-16 nylock, G5	
9	60683	6	Screw, .500-13 x 1.50 std hex, SS	
10	60309	12	Washer, .500 flat 1.060/.090	
11	62221	9	Nut, .500-13 nylock, G5	
12	50215	1	Screw, .500-13 x 4.0 std hex, G5	
13	60388	2	Screw, .500-13 x 1.50 std hex, G5	
14	33234B	1	Weldment, step platform	
15	Page 8	4	Assembly, light	

OPTIONAL FEATURES

Spare Tire:

A	60388	5	Screw, .500-13 x 1.50 std hex, G5
B	60309	10	Washer, .500 flat 1.060/.090
C	35030B	1	Bracket, spare tire holder
D	35031B	1	Plate, spare tire holder
E	60096	5	Nut, .500-20 lug, G5
F	15976	1	Wheel, ST175/80D13, 1360 lb
G	62221	5	Nut, .500-13 nylock, G5
H	10734B	1	Weldment, spare tire holder

LIGHT ASSEMBLY

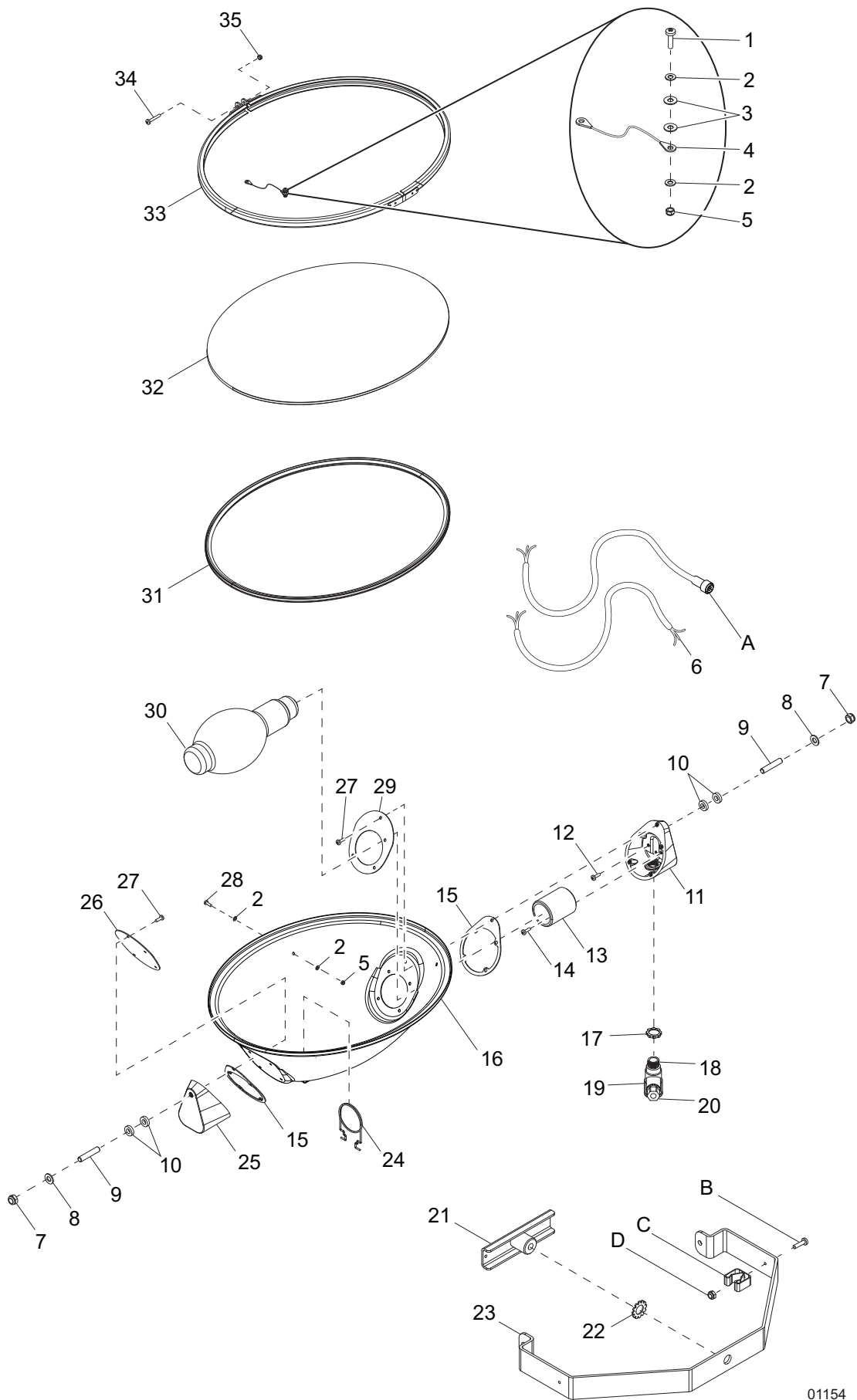

01154

LIGHT ASSEMBLY

Item	Part No.	Qty	Description	Notes
1	13399	1	Screw, M4 x 18 pan phil	
2	13371	4	Washer, #4	
3	13372	2	Washer, #4 nylon	
4	13370	1	Assembly, tether	
5	13395	2	Nut, M4 nylock	
6	13438	1	Cord, power - hard wired	
7	62221	2	Nut, .500-13 nylock, G5	
8	60247	2	Washer, .750 flat 2.020/.090	
9	13392	2	Stud, trunnion mounting	
10	13390	4	Washer, .500 nylon	
11	13374	1	Support, housing/trunnion w/out cord	
12	13393	1	Screw, M5 x 12 phillips green	
13	13381	1	Socket, bulb w/out threaded insert	
14	13396	2	Screw, pan phillips	
15	13378	2	Gasket, silicone	
16	13366	1	Assembly, housing	
17	15861	1	Nut, special, .500NPT lock	
18	13386	1	Fitting, nipple - .500	
19	13387	1	Connector, weathertight - .500	
20	15864	1	Strain relief, .500NPT watertight, .270/.464 ID	
21	13403	1	Handle, T - wing nut	
22	61174	1	Washer, .750 external star	
23	13368	1	Trunnion	
24	13380	1	Bracket, bulb support	
25	13375	1	Support, housing/trunnion w/cord	
26	13377	1	Bracket, non socket end plate	
27	13388	10	Screw, M5 x 12 flg hex, slotted	
28	13394	1	Screw, M4 x 10 pan phil	
29	13376	1	Bracket, socket end plate	
30	11391	1	Bulb, 1000W MH short length	
31	13373	1	Gasket, lens	
32	13369	1	Lens, glass	
33	13367	1	Assembly, aluminum ring	
34	13398	1	Screw, ground	
35	13397	1	Nut, nylock	
--	13311	1	Assembly, light - hard wired	Items 1 - 35
OPTIONAL FEATURES				
<i>Quick Disconnect Light:</i>				
A	13383	1	Cord, power quick disconnect	Replaces item 6
B	60398	1	Screw, 10-32 x .500 pan phil, SS	
C	19041	1	Clip, spring holder	
D	60061	1	Nut, 10-32 nylock	
--	13601	1	Assembly, light - quick disconnect, cord clip	

MAST JUNCTION BOX ASSEMBLY - HARD WIRED LIGHTS

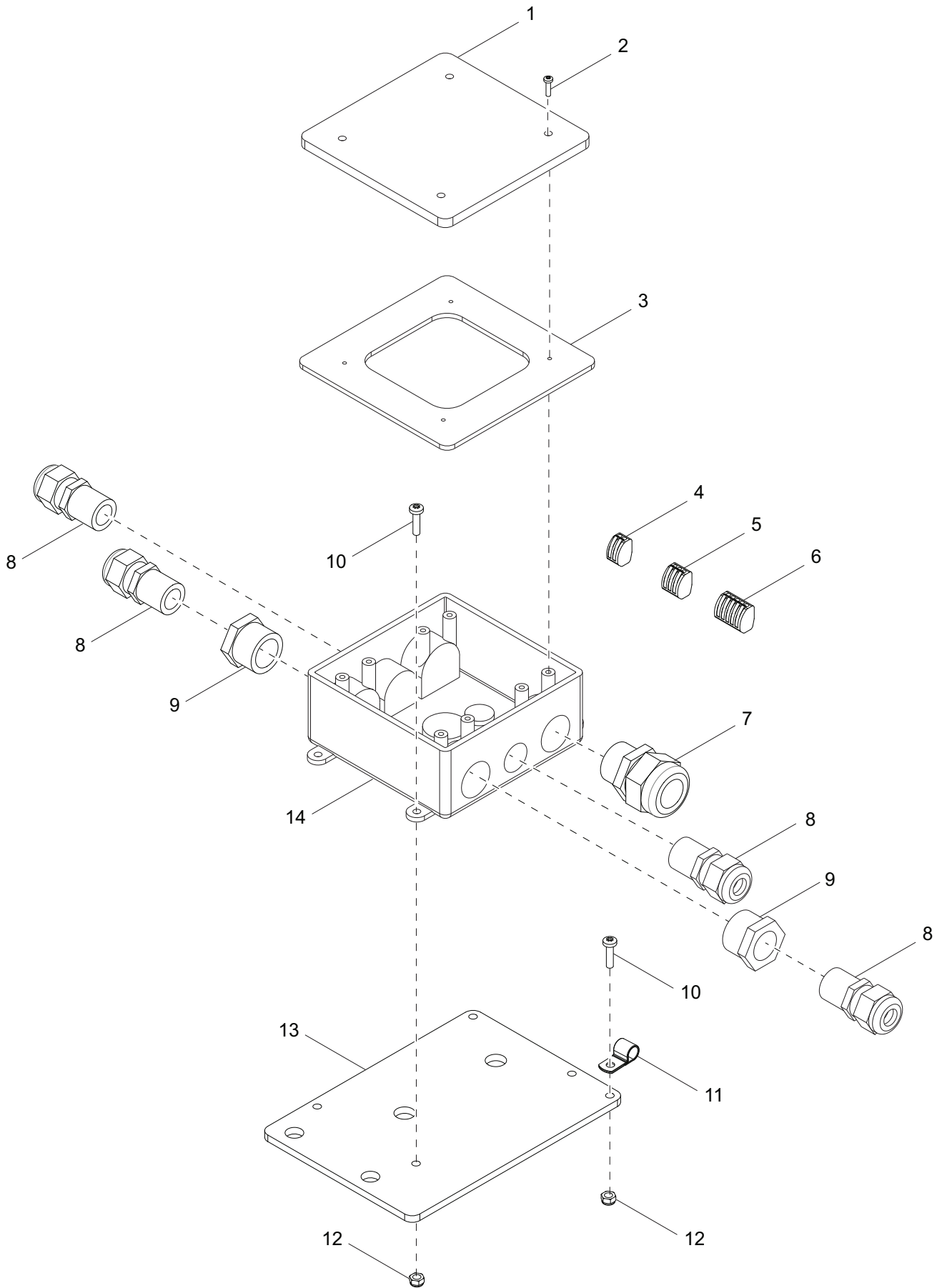

01155

MAST JUNCTION BOX ASSEMBLY - HARD WIRED LIGHTS

Item	Part No.	Qty	Description	Notes
1	12109	1	Cover, box, 2 gang plastic	
2	60424	4	Screw, 6-32 x .750 pan phil, G2	
3	13749	1	Gasket, junction box	
4	66100	4	Connector, 2 position	
5	66101	2	Connector, 3 position	
6	66102	1	Connector, 5 position	
7	15864	4	Strain relief - .500NPT watertight, .270/464 ID	
8	14646	1	Strain relief - .750NPT watertight, .545/709 ID	
9	60755	2	Fitting, strt - .750MNPT x .500FNPT, nylon	
10	60062	5	Screw, 10-32 x .750 pan phil, G2	
11	16143	1	Clamp, tubing - .500	
12	60415	5	Nut, 10-32 nylock, SS	
13	12095B	1	Bracket, junction box - black	
14	12094	1	Box, junction	
--	11789	1	Assembly, mast junction box - hard wired	Items 1 - 14

MAST JUNCTION BOX ASSEMBLY - QUICK DISCONNECT LIGHTS OPTION

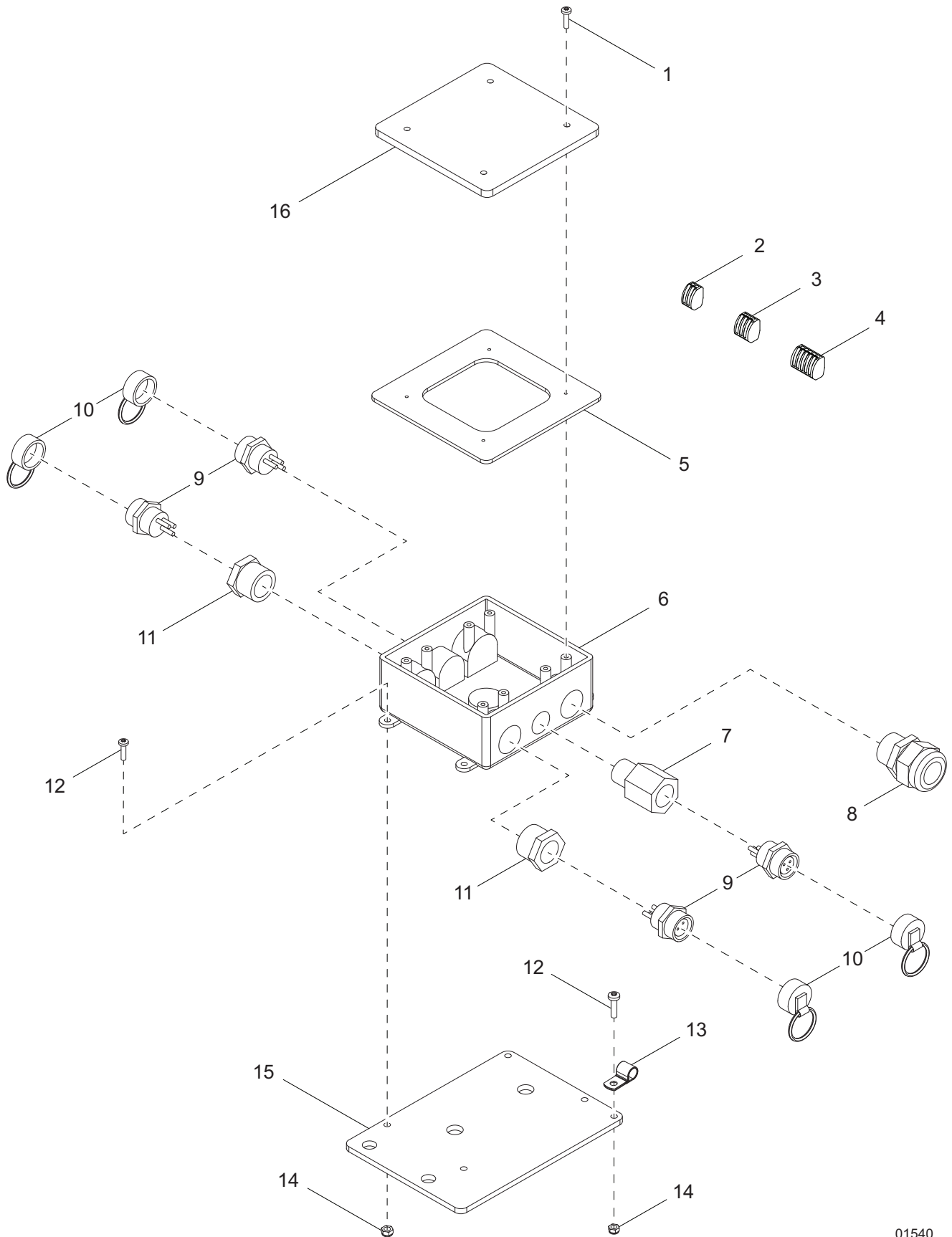

01540

MAST JUNCTION BOX ASSEMBLY - QUICK DISCONNECT LIGHTS OPTION

Item	Part No.	Qty	Description	Notes
1	60424	4	Screw, 6-32 x .750 pan phil, G2, self thread	
2	66100	4	Connector, 2 position	
3	66101	2	Connector, 3 position	
4	66102	1	Connector, 5 position	
5	13749	1	Gasket, junction box	
6	12094	1	Box, junction	
7	12713	1	Fitting, strt - .500MNPT x .500FNPT, steel	
8	14656	1	Strain relief, .750NPT, watertight	
9	15403	4	Connector, quick disconnect - female	
10	12410	4	Assembly, quick disconnect receptacle cap w/chain	
11	60755	2	Fitting, strt - .750MNPT x .500FNPT, nylon	
12	60062	5	Screw, 10-32 x .750 pan phil, G2	
13	16143	1	Clamp, tubing - .500	
14	60415	5	Nut, 10-32 nylock, SS	
15	12095B	1	Bracket, junction box - black	
16	12109	1	Cover, box, 2 gang plastic	
--	11957	1	Assembly, mast junction box - quick disconnect	Items 1 - 16

MAST ASSEMBLY

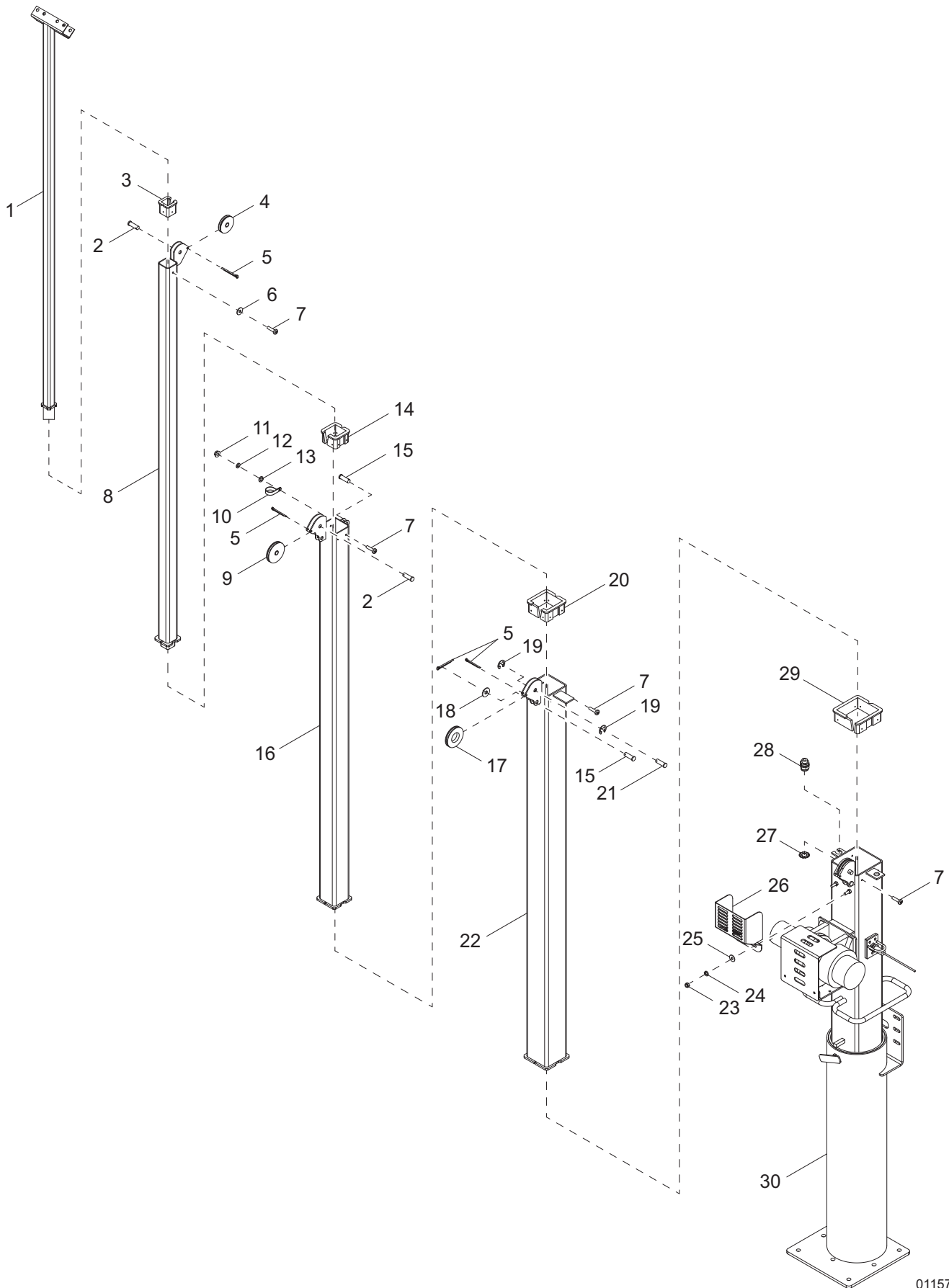

01157

MAST ASSEMBLY

Item	Part No.	Qty	Description	Notes
1	32015B	1	Weldment, mast section, 1.25 in	
2	63279	2	Pin, clevis - .500 dia x .780	
3	32409	1	Shim, 2 x 2 tube	
4	32524	1	Sheave, 2.50 in	
5	15380	4	Pin, cotter - .125 x 1.25	
6	60067	2	Washer, #10 flat .435/.060, SS	
7	32569	14	Screw, 8-16 x .375 pan phil, SS	
8	32010B	1	Weldment, mast section, 2 in	
9	14262	1	Sheave, 3 in	
10	15627	1	Clamp, tubing - .625 heavy duty	
11	60140	1	Nut, .375-16 hex, G5	
12	60206	1	Washer, .375 split lock	
13	60386	1	Washer, .375 flat .993/.064	
14	13789	1	Shim, 3 x 3 tube	
15	63325	2	Pin, clevis - .500 dia x 1.063	
16	32007B	1	Weldment, mast section - 3 in	
17	33736	1	Assembly, pulley	
18	60309	1	Washer, .500 flat 1.060/.090	
19	63281	1	Clip, E-ring	
20	13790	1	Shim, 4 x 4 tube	
21	63280	1	Pin, grooved clevis - .500 dia x .780	
22	32004B	1	Weldment, mast section, 4 in	
23	60285	2	Nut, .312-18 hex, G2	
24	60271	2	Washer, .312 split lock	
25	60119	1	Washer, .312 flat .875/.070	
26	33395B	1	Guard, pulley	
27	15861	1	Nut, .500NPT lock	
28	14871	1	Strain relief, .500NPT, .500 cord	
29	32408	1	Shim, 5 x 5 tube	
30	<i>Page 16</i>	1	Assembly, mast bottom	
--	34132	1	Cable, .188 in. x 116 in., SS	Attaches to item 30
--	34128	1	Cable, .188 in. x 69.25 in., SS	Attaches to item 22
--	34129	1	Cable, .188 in. x 69.75 in., SS	Attaches to item 16
--	34130	1	Cable, .188 in. x 67.875 in., SS	Attaches to item 8
--	33397	1	Coil cord	
--	33228	1	Assembly, vertical mast	Items 1 - 30
--	10770	1	Wire group - coil cord ground extension	

MAST ASSEMBLY - BOTTOM POST

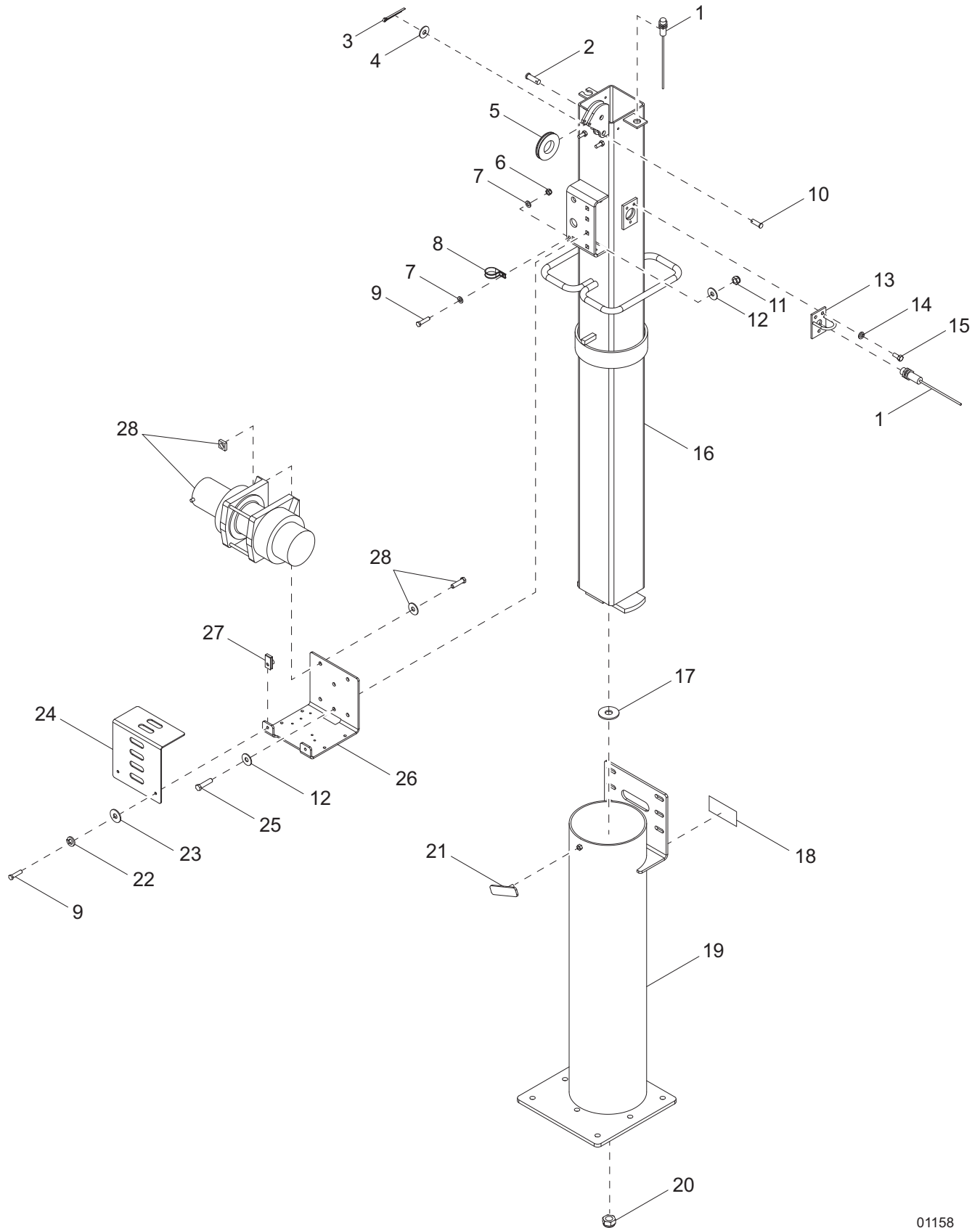

01158

MAST ASSEMBLY - BOTTOM POST

Item	Part No.	Qty	Description	Notes
1	31757	1	Sensor, proximity	Qty of 2 sensors per group
2	63325	1	Pin, clevis - .500 dia x 1.063	
3	15380	1	Pin, cotter - .125 x 1.25	
4	60309	1	Washer, .500 flat 1.060/.090	
5	33736	1	Assembly, pulley	
6	60144	1	Nut, .250-20 nylock, G5	
7	60696	2	Washer, .250 flat .625/.050, SS	
8	16143	1	Clamp, tubing - .500	
9	60393	3	Screw, .250-20 x 1.0 std hex, G5	
10	63272	1	Pin, clevis - .500 dia x 1.25	
11	60358	2	Nut, .375-16 nylock, G5	
12	60386	4	Washer, .375 flat .993/.064	
13	13796B	1	Weldment, proximity sensor bracket	
14	60271	3	Washer, .312 split lock	
15	60168	3	Screw, .312-18 x .750 std hex, G5	
16	33247B	1	Weldment, mast bottom - 5 in	
17	60247	1	Washer, .750 flat 2.020/.130	
18	50197	0.75 ft	Weatherstripping - .06 x 1.0	
19	33224B	1	Weldment, mast tube	
20	60584	1	Nut, .750-10 nylock, G5	
21	11649Z	1	Weldment, T-bolt	
22	60286	2	Washer, .250 split lock	
23	60243	2	Washer, .250 flat .735/.060	
24	33822B	1	Bracket, winch cover	
25	60352	2	Screw, .375-16 x 1.25 std hex, G5	
26	33858B	1	Bracket, winch mounting	
27	61143	2	Nut, .250-20 U-clip - short type	
28	34293	1	Winch, electric - 1200 lb hoist	
--	17936	1	Wire group - electric winch	
--	31759	1	Wire group - winch battery power cables	
--	31758	1	Wire group - winch power cables	
--	31757	1	Wire group - proximity sensor	

ROOF AND DOORS TO UNIT

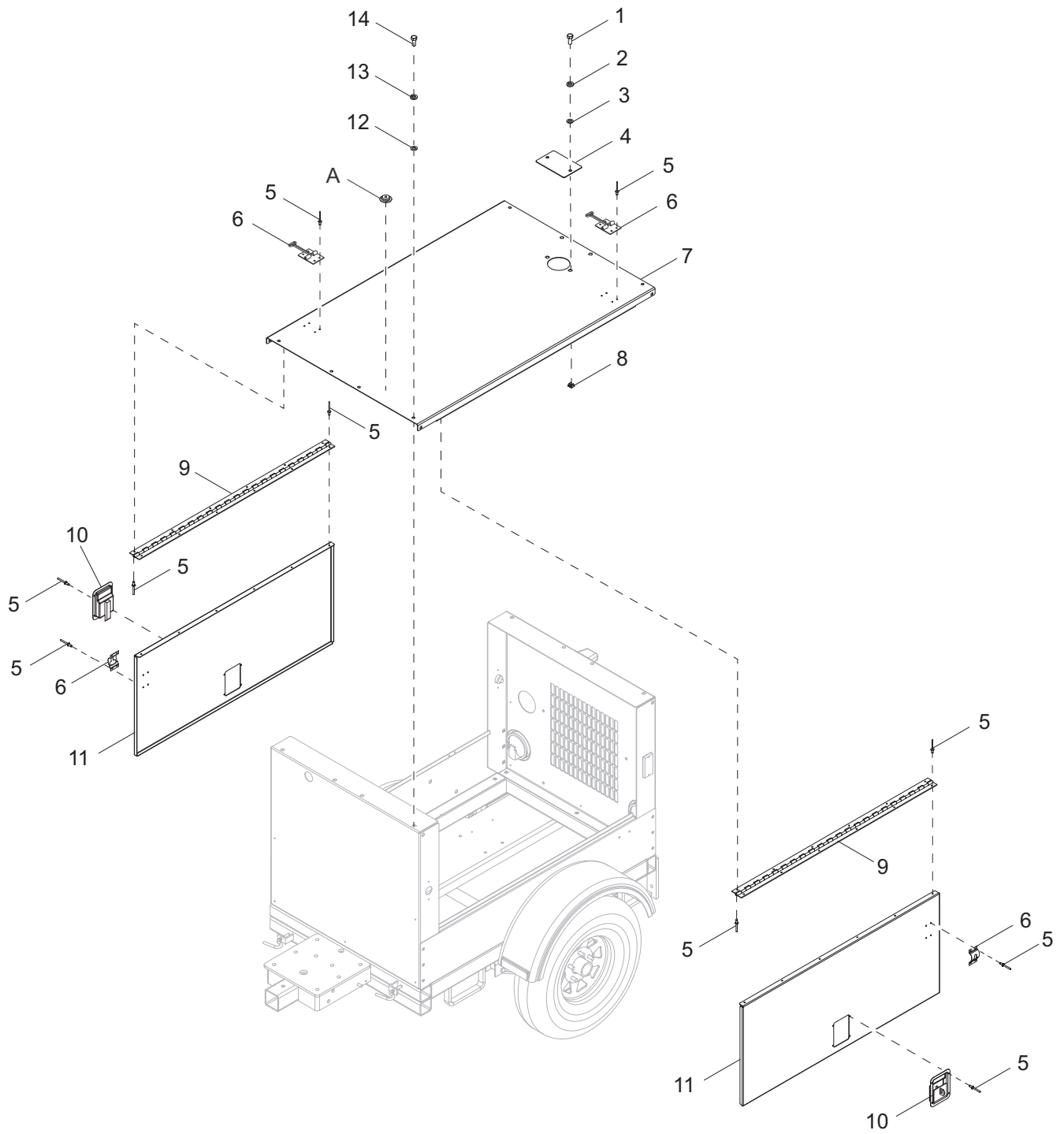

01226

ROOF AND DOORS TO UNIT

Item	Part No.	Qty	Description	Notes
1	60507	2	Screw, .312-18 x 1.0 std hex, SS	
2	60701	2	Washer, .312 split lock, SS	
3	60340	2	Washer, .312 flat .875/.040, SS	
4	11096W	1	Panel, radiator access	
5	60268	48	Rivet, .188 dia x .126 to .250 grip, SS	
6	12605	2	Door latch, T-style, SS	
7	11062W	1	Panel, top	
8	15425	2	Nut, .312-18 cage	
9	11095	2	Hinge, continuous - 43.0	
10	15123	2	Latch, paddle - w/7lb spring	
11	11066W	2	Panel, door	
12	60698	10	Washer, .375 flat .875/.040, SS	
13	60703	10	Washer, .375 split lock, SS	
14	60690	10	Screw, .375-16 x 1.0 std hex, SS	

OPTIONAL FEATURES

Level Indicator:

A	14433	1	Level, eye
---	-------	---	------------

FRONT, REAR, AND SIDE PANELS TO UNIT

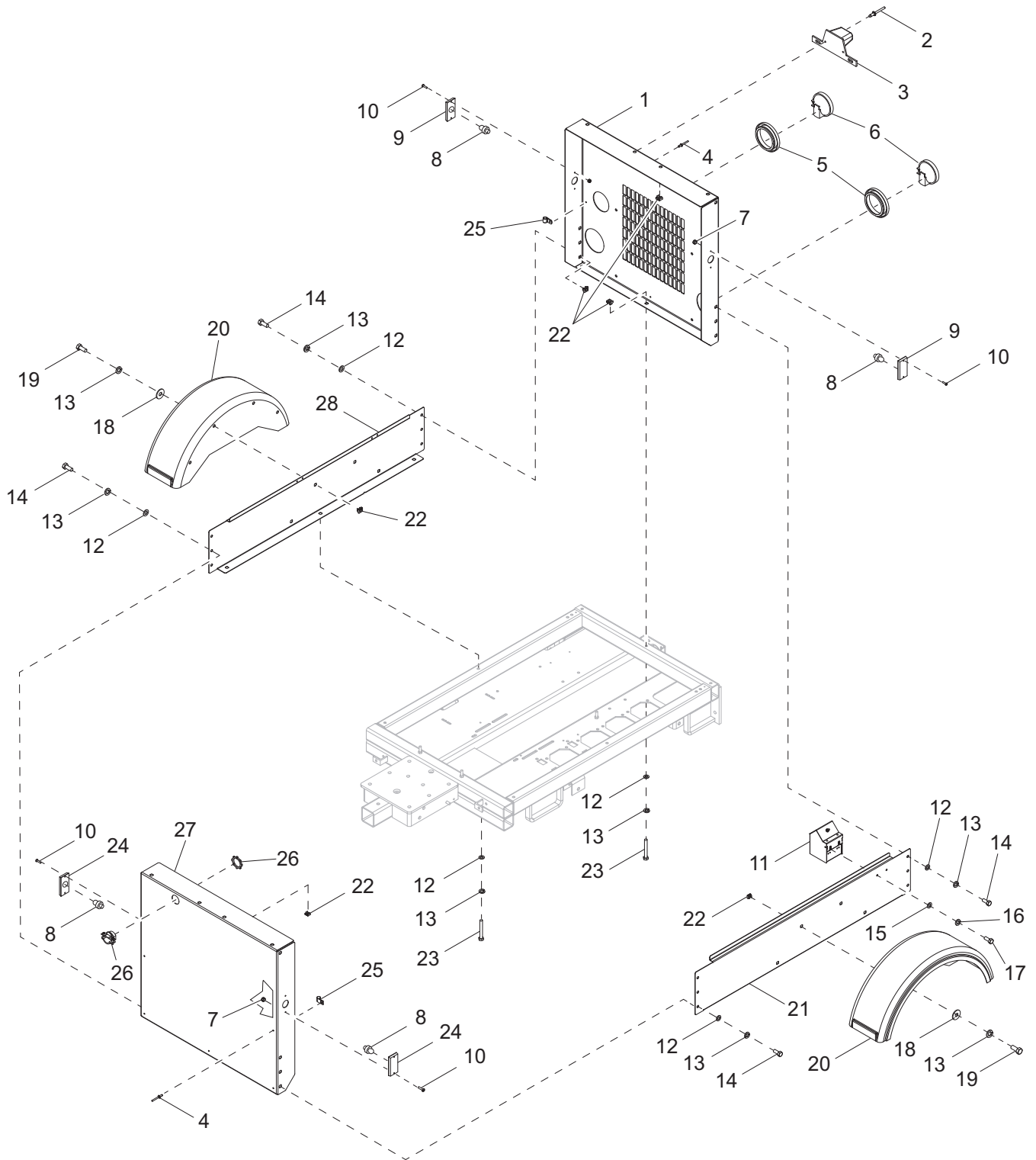

01227

FRONT, REAR, AND SIDE PANELS TO UNIT

Item	Part No.	Qty	Description	Notes
1	11060W	1	Panel, rear	
2	60423	2	Rivet, .188 dia x .250 to .375 grip	
3	10223	1	Assembly, license plate light/holder	
4	60268	10	Rivet, .188 dia x .126 to .250 grip, SS	
5	10221	2	Grommet, rear light, rubber 4.5 in	
6	10220	2	Light, rear tail/turn, round, no grommet	
7	60270	8	Nut, 8-32 nylock, class 6	
8	65661	4	Bulb - light, clearance marker	
9	66372	2	Lens, red - light, clearance marker	
10	61180	8	Screw, 8-32 x .750 pan phil, SS	
11	Page 22	1	Assembly, mast switch box	
12	60698	21	Washer, .375 flat .875/.040, SS	
13	60703	29	Washer, .375 split lock, SS	
14	60690	12	Screw, .375-16 x 1.0 std hex, SS	
15	60696	2	Washer, .250 flat .625/.050, SS	
16	60704	2	Washer, .250 split lock, SS	
17	60684	2	Screw, .259-20 x .875 std hex, SS	
18	60729	8	Washer, .375 fender 1.50/.090	
19	60295	8	Screw, .375-16 x .750 std hex, SS	
20	16560	2	Fender, plastic shell	
21	12015W	1	Panel, side - left	
22	60657	37	Nut, .375-18 cage	
23	60689	9	Screw, .375-16 x 4.0 std hex, SS	
24	66373	2	Lens, amber - light, clearance marker	
25	15628	10	Clamp, wire .38 plastic	
26	66425	1	Strain relief - 1.25 Romex w/nut	
27	33748W	1	Panel, front	
28	12014W	1	Panel, side - right	
--	12101	1	Wiring, trailer	

MAST SWITCH BOX ASSEMBLY

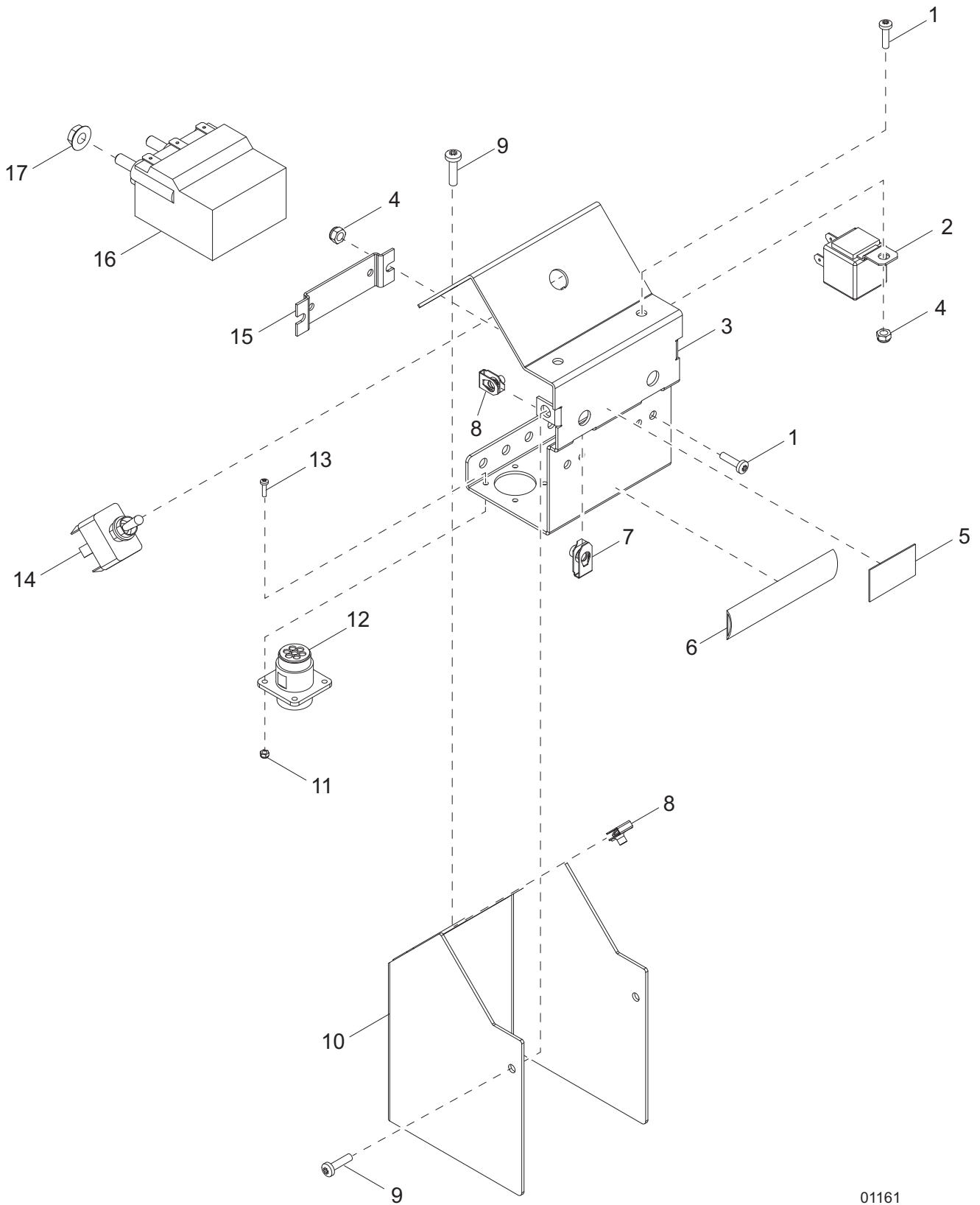

01161

MAST SWITCH BOX ASSEMBLY

Item	Part No.	Qty	Description	Notes
1	60277	4	Screw, 10-32 x .500 pan phil, G2	
2	65049	2	Relay, 12V 30/40A NO w/diode	
3	33750B	1	Panel, box - mast switch	
4	60061	4	Nut, 10-32 nylock	
5	50197	.125 ft	Weatherstripping - .06 x 1.0	
6	50187	.33 ft	Seal, door - D-shaped (.750)	
7	61143	2	Nut, .250-20 U-clip - short type	
8	63105	4	Nut, 8-32 U-clip, G5	
9	60526	4	Screw, 8-32 x .500 pan phil, G2	
10	33751B	1	Panel, cover - mast switch	
11	60758	4	Nut, 4-40 nylock, G2	
12	61229	1	Connector, amp - 7 position receptacle, flange	
13	62187	4	Screw, 4-40 x .500 pan phil, SS	
14	65707	1	Switch, toggle - SPDT, spring, weatherproof	
15	33255B	1	Bracket, electric winch	
16	11293	1	Contactactor, 12V electric winch	
17	60036	4	Nut, M6-1.0 sflg, G8.8	
--	33471	1	Assembly, mast switch box	Items 1 - 17

CONTROL BOX TO UNIT

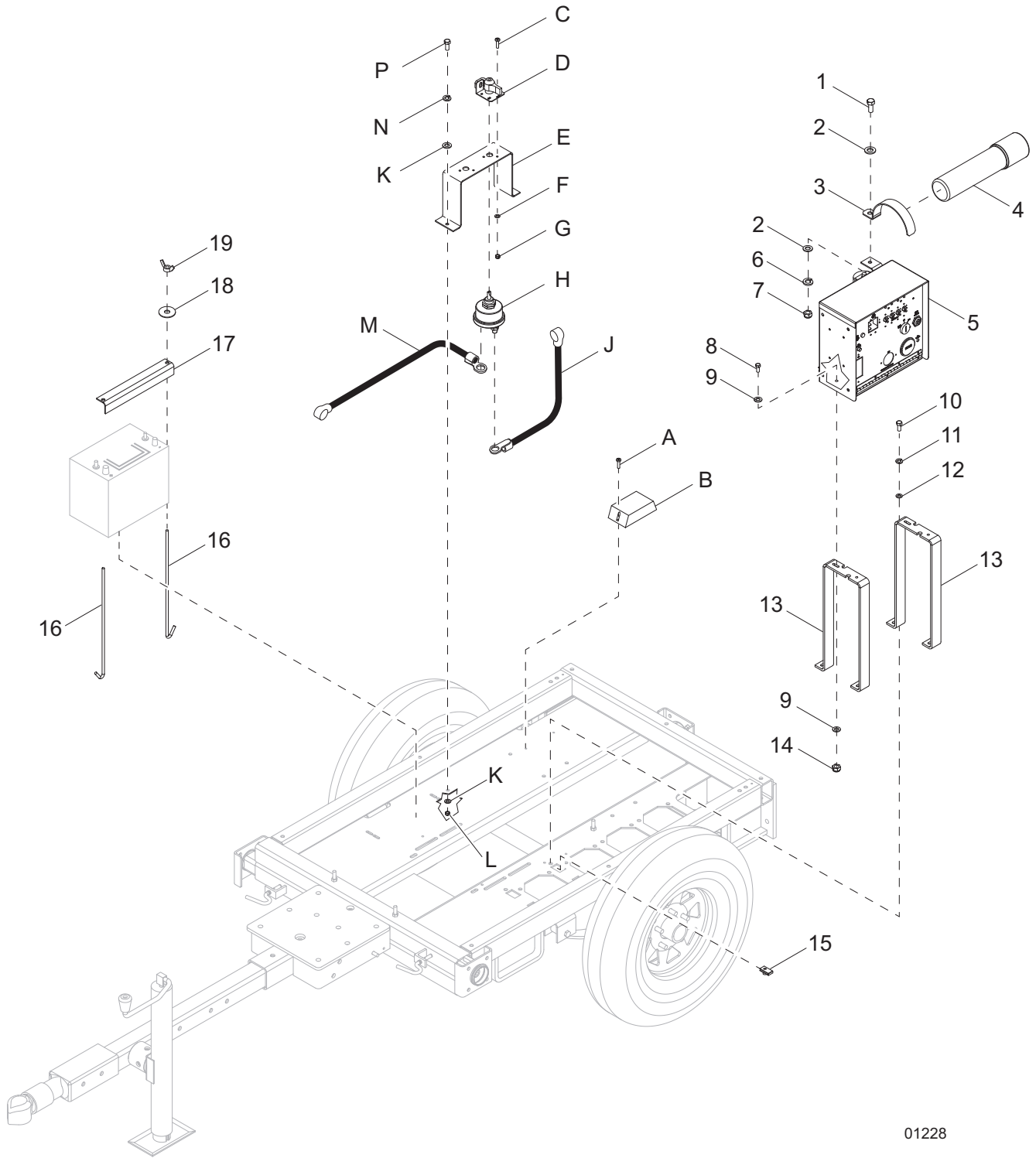

01228

CONTROL BOX TO UNIT

Item	Part No.	Qty	Description	Notes
1	60690	1	Screw, .375-16 x 1.0 std hex, SS	
2	60698	2	Washer, .375 flat .875/.040, SS	
3	10241	1	Clamp, 2.50 - manual holder	
4	11121	1	Manual holder tube, 14 in. - black	
5	Page 26	1	Assembly, control box	
6	60703	1	Washer, .375 split lock, SS	
7	60140	1	Nut, .375 hex, G5	
8	60684	4	Screw, .250-20 x .875 std hex, SS	
9	60696	8	Washer, .250 flat .625/.050, SS	
10	60256	4	Screw, .312-18 x 1.50 std hex, G5, full thread	
11	60271	4	Washer, .312 split lock	
12	60119	4	Washer, .312 flat .875/.070	
13	10692B	2	Bracket, control box mounting	
14	60144	4	Nut, .250-20 nylock, G5	
15	62086	4	Nut, .312-18 U-clip - short type	
16	14146	2	Bolt, J - .250-20 x 10.0	
17	12924B	1	Angle, battery hold down	
18	60089	2	Washer, .265 fender 1.250/.060	Included w/item 16
19	60090	2	Nut, .250-20 wing, G5	Included w/item 16

OPTIONAL FEATURES

Battery Charger:

A	60419	2	Screw, 6-32 x .500 flg hex, G2, self-tapping
B	65326	1	Charger, battery 2A
--	21259	1	Decal, battery charger

Battery Disconnect:

C	60277	2	Screw, 10-32 x .500 pan phil, G2
D	65499	1	Assembly, switch lockout lever
E	13654B	1	Bracket, battery disconnect
F	60067	2	Washer, #10 flat .435/.060, SS
G	60061	2	Nut, 10-32 nylock
H	65498	1	Switch, disconnect
J	68544	1	Cable, battery - 18 in., 4GA red, .375 lug
K	60119	2	Washer, .312 flat .875/.070
L	60303	2	Nut, .312-18 nylock, G2
M	68543	1	Cable, battery - 24 in., 4GA red w/boot, .375 lug
N	60271	2	Washer, .312 split lock
P	60028	2	Screw, .312-18 x 1.0 std hex, G5

CONTROL BOX ASSEMBLY

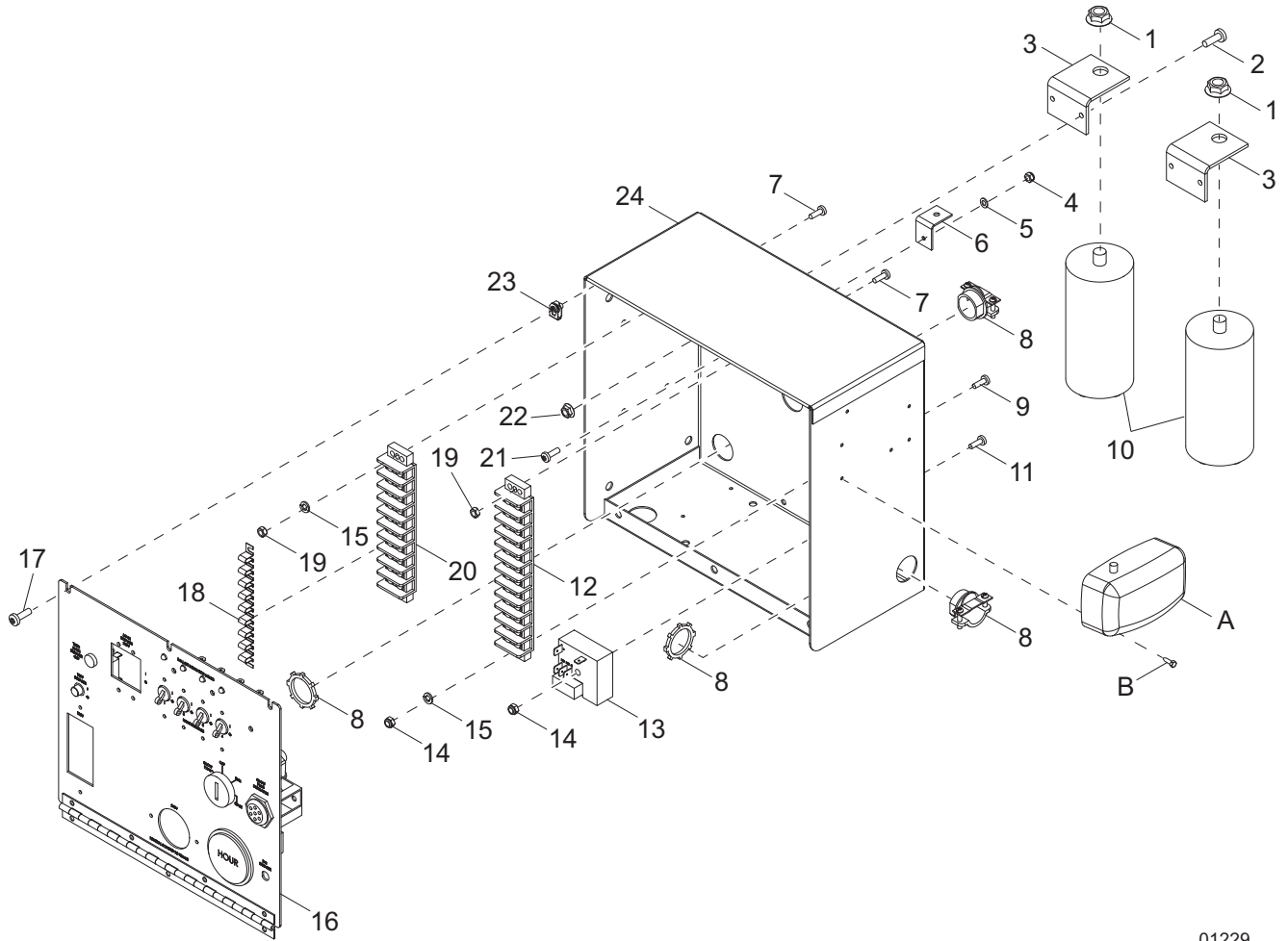

01229

CONTROL BOX ASSEMBLY

Item	Part No.	Qty	Description	Notes
1	60148	2	Nut, M12-1.75 sflg, G8.8	
2	60398	4	Screw, 10-32 x .500 pan phil, SS	
3	13690B	2	Bracket, capacitor	
4	60144	1	Nut, .250-12 nylock, G5	
5	60243	1	Washer, .250 flat .735/.060	
6	32731B	1	Bracket, manual holder	
7	60062	3	Screw, 10-32 x .750 pan phil, G2	
8	14219	5	Strain relief - .750 Romex w/nut	
9	60397	1	Screw, 10-32 x 1.0 pan phil, G2	
10	65959	2	Capacitor, dual 24 μ F sealed, stud mount	
11	60396	1	Screw, 10-32 x 1.250 pan phil, G2	
12	14139	1	Block, terminal - 12 position, 30A, 600V	
13	14201	1	Relay, 10A SPDT 12VDC, time delay - 15 second	
14	60061	1	Nut, 10-32 nylock	
15	60252	2	Washer, #10 split lock	
16	Page 28	1	Assembly, control panel	MLT3060KV/MV only
	Page 30	1	Assembly, control panel	MLT3080KV only
17	60526	6	Screw, 8-32 x .500 pan phil, G2	
18	15125	1	Jumper	
19	14231	2	Nut, 10-32 hex, G2	
20	14203	1	Block, terminal - 10 position, 30A, 600V	
21	60690	1	Screw, .375-16 x 1.0 std hex, SS	
22	61045	4	Nut, 10-32 sflg	
23	63105	6	Nut, 8-32 U-clip, G5	
24	13666B	1	Box, control	
--	10405	1	Assembly, control box - Mitsubishi, 6kW	MLT3060MV only
--	17790	1	Assembly, control box - Kubota, 6kW	MLT3060KV only
--	35088	1	Assembly, control box - Kubota, 8kW	MLT3080KV only
--	35270	1	Wire group - 6kW control box	MLT3060KV/MV only
--	35310	1	Wire group - 8kW control box	MLT3080KV only
OPTIONAL FEATURES				
<i>Interior Light:</i>				
A	11947	1	Light, interior w/switch	
B	60364	4	Screw, 10-16 x .500 std hex, G2, self-drilling	

CONTROL PANEL ASSEMBLY - MLT3060KV, MLT3060MV

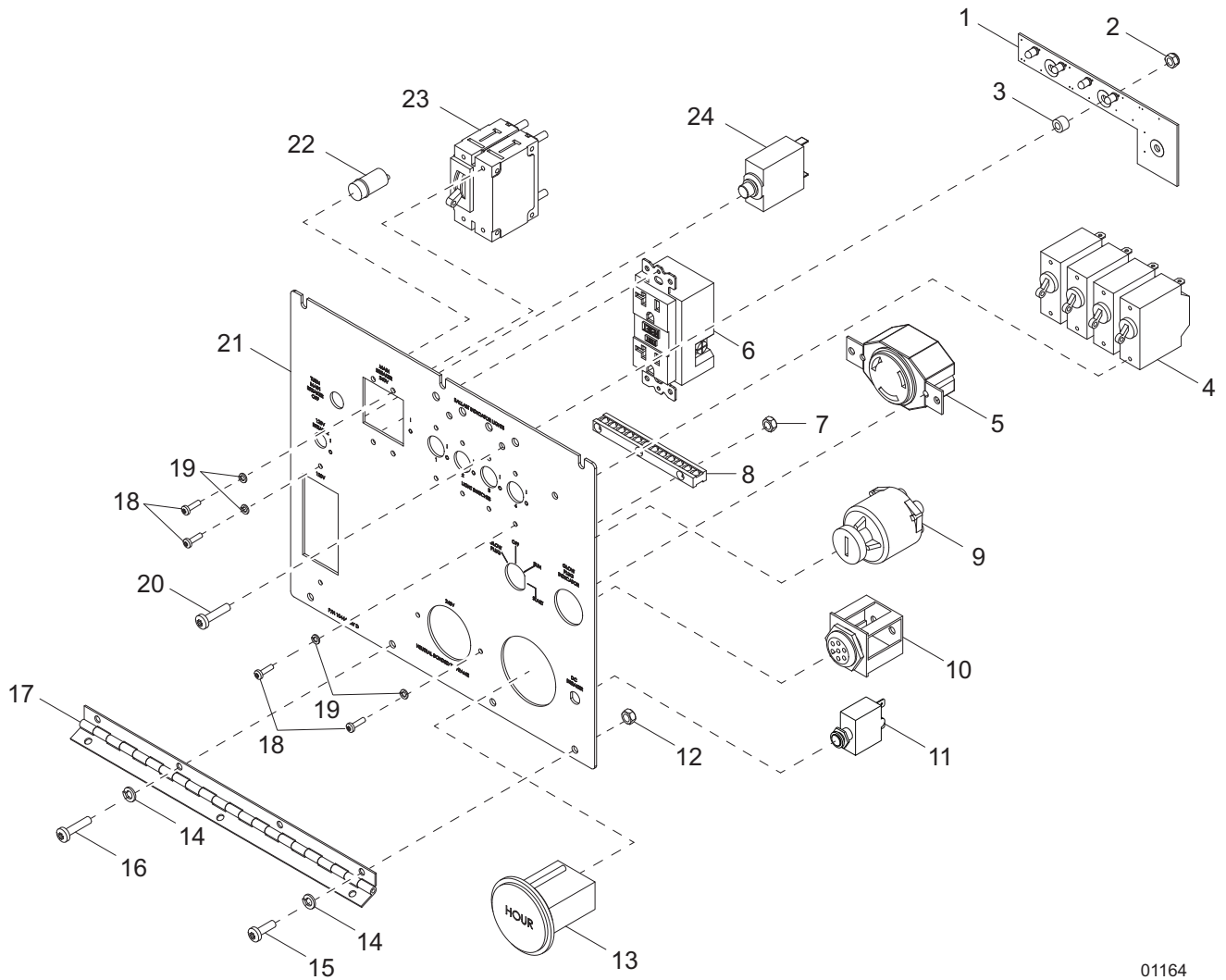

01164

CONTROL PANEL ASSEMBLY - MLT3060KV, MLT3060MV

Item	Part No.	Qty	Description	Notes
1	66423	1	PCB, LED lights w/connector	
2	60061	3	Nut, 10-32 nylock	
3	66257	3	Spacer, .2 ID x .375 OD x .25 long, plastic	
4	14249	4	Breaker, 15A, 120V, 1-pole	
5	14137	1	Receptacle, 240V/30A twist-lock	
6	14130	1	Receptacle, 120V/20A GFI	
7	60318	2	Nut, 8-32 hex, G5	
8	14204	1	Kit, ground bar	
9	15195	1	Switch, key	
10	16694	1	Glow plug indicator	MLT3060MV only
11	65850	1	Breaker, 10A, 240V, 1-pole, push button	
12	14231	2	Nut, 10-32 hex, G2	
13	15085	1	Gauge, hour meter	
14	60252	4	Washer, #10 split lock	
15	60277	2	Screw, 10-32 x .500 pan phil, G2	
16	60406	2	Screw, 8-32 x 1.0 pan phil, SS	
17	13677	1	Hinge, continuous - 11 in	
18	60405	16	Screw, 6-32 x .250 pan phil, G2	
19	60058	16	Washer, #6 split lock	
20	60062	3	Screw, 10-32 x .750 pan phil, G2	
21	10444	1	Panel, control - Mitsubishi, 6kW	MLT3060MV only
	10441	1	Panel, control - Kubota, 6kW	MLT3060KV only
22	65388	1	Light, indicator red, 12VDC	
23	65963	1	Breaker, 30A, 250V, 2-pole, stud terminal w/aux	
24	65849	1	Breaker, 10A, 120V, 1-pole, push button	
--	10443	1	Assembly, control panel - Mitsubishi	Items 1 - 34
--	10440	1	Assembly, control panel - Kubota	Items 1 - 9 & 11 - 34
--	35267	1	Wire group - 20A GFCI	
--	35268	1	Wire group - 30A twist-lock	
--	35269	1	Wire group - light switches	
--	35266	1	Wire group - LED light board	
--	35271	1	Wire group - 6kW control box	

CONTROL PANEL ASSEMBLY - MLT3080KV

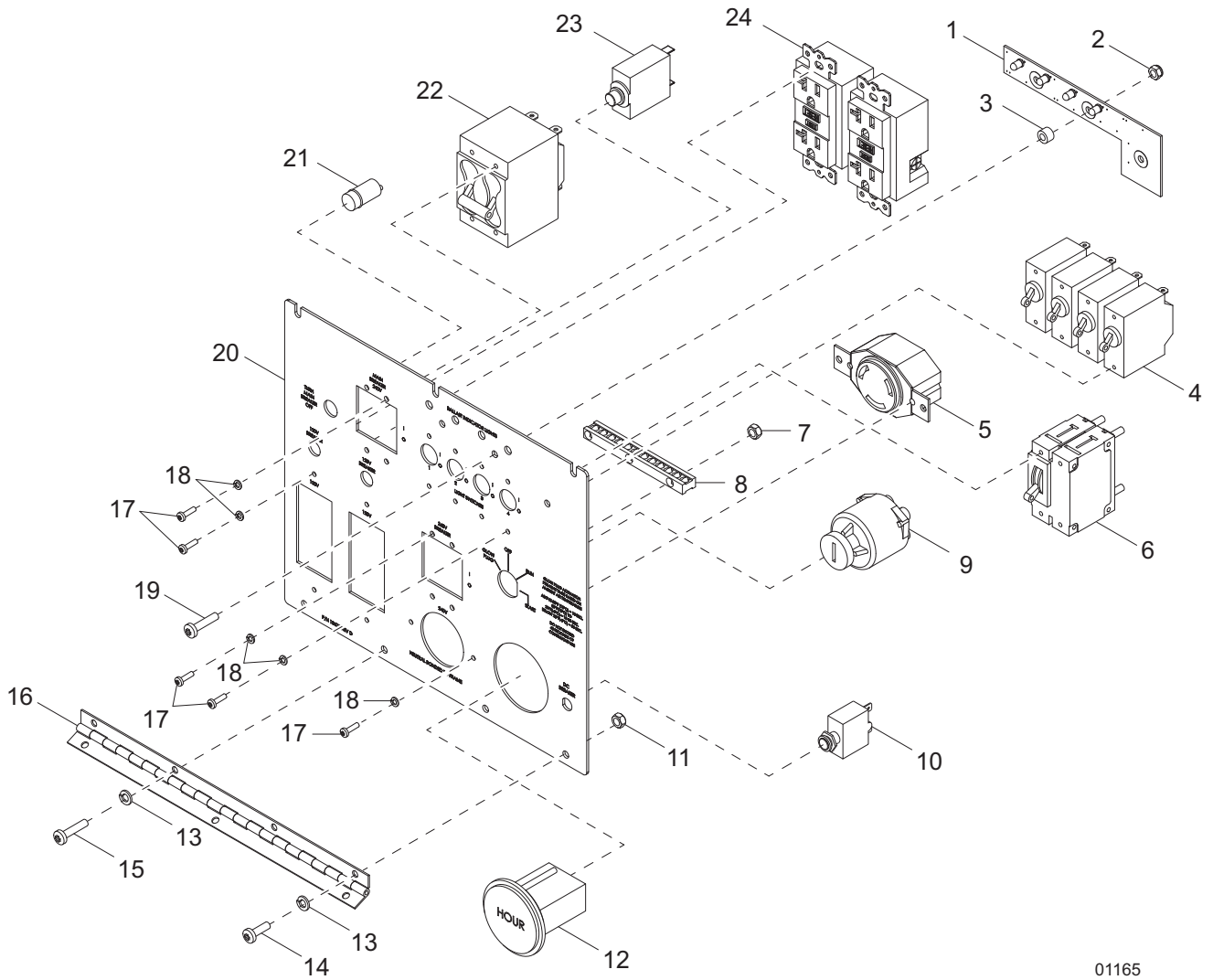

01165

CONTROL PANEL ASSEMBLY - MLT3080KV

Item	Part No.	Qty	Description	Notes
1	66423	1	PCB, LED lights w/connector	
2	60061	3	Nut, 10-32 nylock	
3	66257	3	Spacer, .2 ID x .375 OD x .25 long, plastic	
4	14249	4	Breaker, 15A, 120V, 1-pole	
5	14137	1	Receptacle, 240V/30A twist-lock	
6	65963	1	Breaker, 30A, 250V, 2-pole, stud terminal w/aux	
7	60318	2	Nut, 8-32 hex, G5	
8	14204	1	Kit, ground bar	
9	15195	1	Switch, key	
10	65850	1	Breaker, 10A, 240V, 1-pole, push button	
11	14231	2	Nut, 10-32 hex, G2	
12	15085	1	Gauge, hour meter	
13	60252	4	Washer, #10 split lock	
14	60277	2	Screw, 10-32 x .500 pan phil, G2	
15	60406	2	Screw, 8-32 x 1.00 pan phil, SS	
16	13677	1	Hinge, continuous - 11 in	
17	60405	22	Screw, 6-32 x .250 pan phil, G2	
18	60058	22	Washer, #6 split lock	
19	60062	3	Screw, 10-32 x .750 pan phil, G2	
20	13675	1	Panel, control - Kubota, 8kW	
21	65388	1	Light, indicator red, 12VDC	
22	65864	1	Breaker, 40A, 250V, 2-pole, screw terminal w/aux	
23	65849	1	Breaker, 10A, 120V, 1-pole, push button	
24	14130	2	Receptacle, 120V/20A GFI	
--	13884	1	Assembly, control panel - Kubota	Items 1 - 24
--	35309	1	Wire group - 20A GFCI	
--	68271	1	Wire group - 30A twist-lock	
--	35269	1	Wire group - light switches	
--	35266	1	Wire group - LED light board	
--	35310	1	Wire group - 8kW control box	

COOLING SYSTEM ASSEMBLY

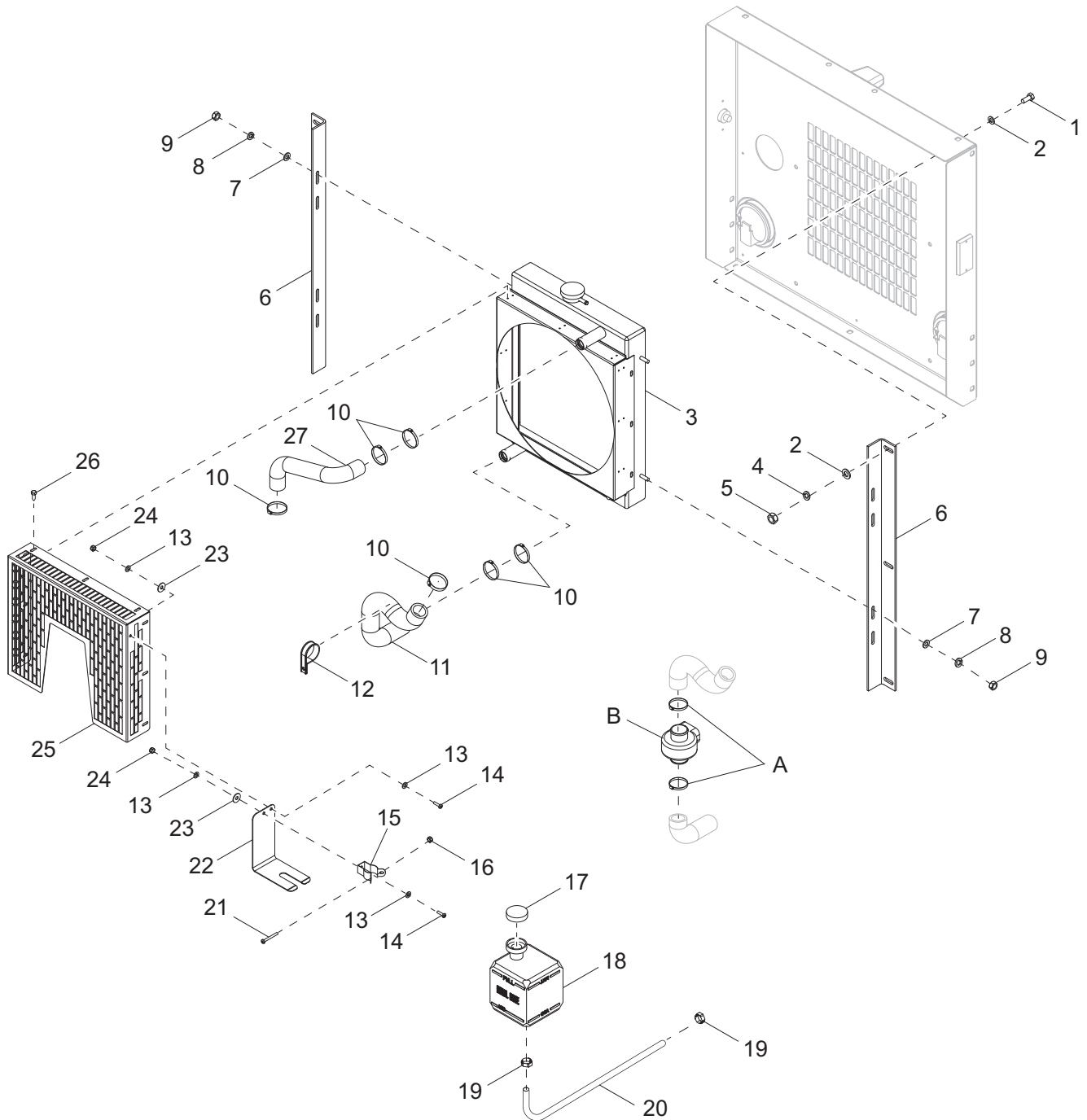

01230

COOLING SYSTEM ASSEMBLY

Item	Part No.	Qty	Description	Notes
1	60690	6	Screw, .375-16 x 1.0 std hex, SS	
2	60698	12	Washer, .375 flat .875/.040, SS	
3	13924	1	Radiator, w/fan guard	
4	60703	6	Washer, .375 split lock, SS	
5	60140	6	Nut, .375-16 hex, G5	
6	11135B	2	Bracket, radiator	
7	60119	4	Washer, .312 flat .875/.070	
8	60271	4	Washer, .312 split lock	
9	60032	4	Nut, M8-1.25 hex, G8.8	
10	15422	6	Clamp,hose - SAE 020 (.75-1.75)	
11	12350	1	Hose, radiator - lower, Kubota	MLT3060/80KV
	16688	1	Hose, radiator - lower, Mitsubishi	MLT3060MV
12	60716	1	Clamp, tubing - 1.50 light duty	
13	60067	4	Washer, #10 flat .435/.060, SS	
14	61180	2	Screw, 10-32 x .750 pan phil, SS	
15	19726	1	Clamp, overflow jug	
16	60144	1	Nut, .250-20 nylock, G5	
17	19714	1	Cap, overflow jug	
18	20287	1	Jug, overflow - 2 qt	
19	60777	2	Clamp, hose - .312, crimp style	
20	50018	1.67 ft	Hose, fuel - .312 ID	
21	60414	1	Screw, .250-20 x 1.50 std hex, G5	
22	22419B	1	Bracket, support overflow jug - black	
23	60696	2	Washer, .250 flat .625/.050, SS	
24	60061	2	Nut, 10-32 nylock	
25	11413B	1	Fan guard	
26	60364	9	Screw, 10-16 x .500 std hex, G2, self-drilling	
27	16687	1	Hose, radiator - upper, Kubota	MLT3060/80KV
	32383	1	Hose, radiator - upper, Mitsubishi	MLT3060MV

OPTIONAL FEATURES

Engine Heater:

A	15422	2	Clamp, hose - SAE 020 (.75-1.75)
B	65649	1	Heater, engine - lower radiator hose, 1 in. dia

ENGINE AND GENERATOR TO UNIT

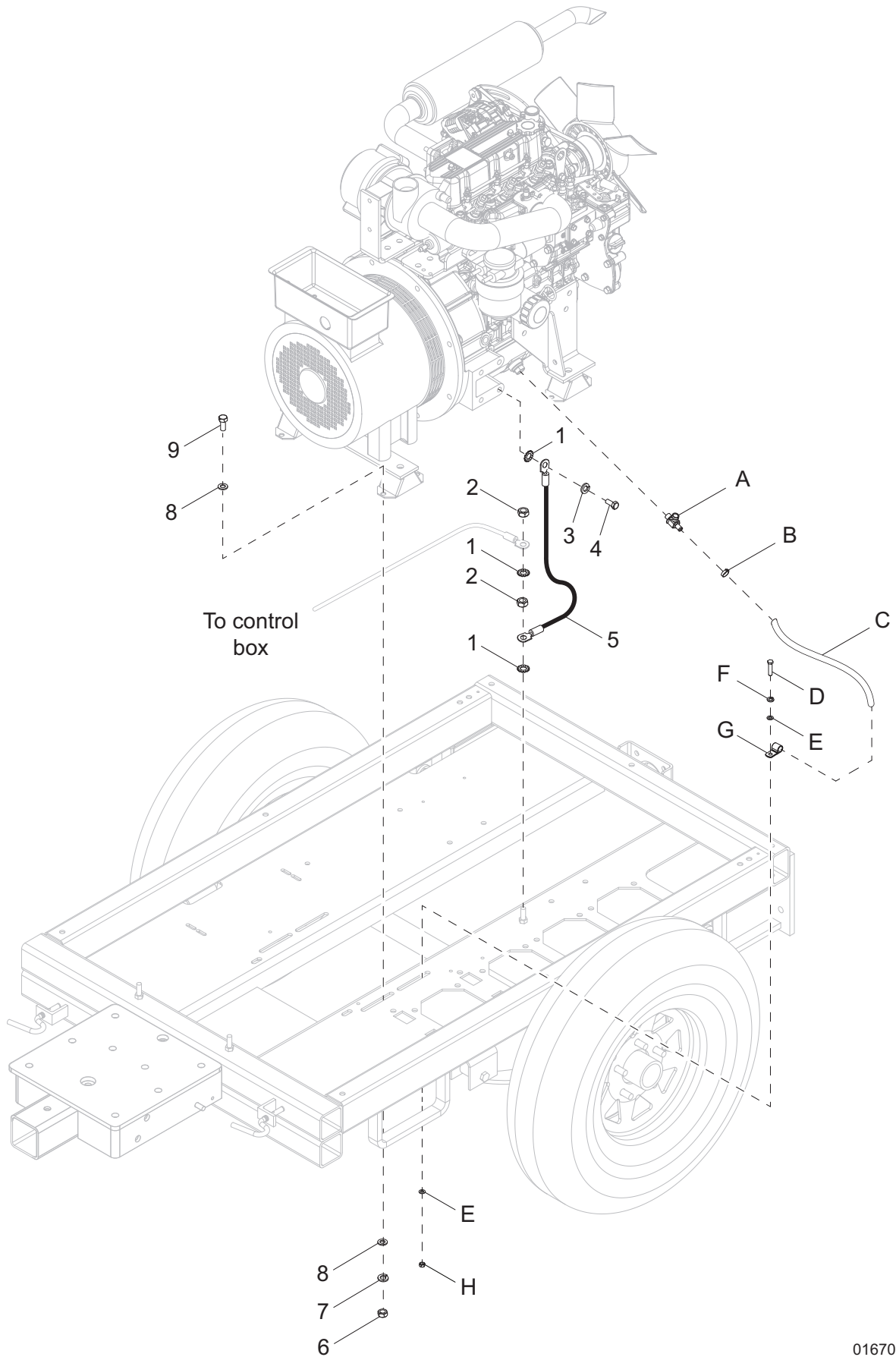

01670

ENGINE AND GENERATOR TO UNIT

Item	Part No.	Qty	Description	Notes
1	60747	3	Washer, .375 internal star	
2	60140	2	Nut, .375-16 hex, G5	
3	60026	1	Washer, M10 split lock	
4	60495	1	Screw, M10-1.25 x 16 std hex, G8.8	
5	11923	1	Assembly, wire - engine/chassis ground	
6	60140	8	Nut, .375-16 hex, G5	
7	60206	8	Washer, .375 split lock	
8	60698	16	Washer, .375 flat .875/.040, SS	
9	60205	8	Screw, .375-16 x 1.0 std hex, G5	

OPTIONAL FEATURES

Drain Valve:

A	60774	1	Valve, drain with nipple	MLT3060/80KV
	60766	1	Valve, drain with nipple	MLT3060MV
B	60365	1	Clamp, hose - SAE 010 (.56-1.06)	MLT3060/80KV
	60777	1	Clamp, hose - .312, crimp style	MLT3060MV
C	68327	1	Hose, .625 in., 200 psi, (22 in)	MLT3060/80KV
	50051	1.67 ft	Hose, fuel - .375 ID, 50 psi, SAE 30R7	MLT3060MV
D	60205	1	Screw, .375-16 x 1.0 std hex, G5	MLT3060/80KV
E	60698	2	Washer, .375 flat .875/.040, SS	MLT3060/80KV
F	60206	1	Washer, .375 split lock	MLT3060/80KV
G	60716	1	Clamp, tubing - 1.50 light duty	MLT3060/80KV
H	60144	1	Nut, .25-20 nylock, G5	MLT3060/80KV

ENGINE ASSEMBLY - MITSUBISHI LEFT SIDE

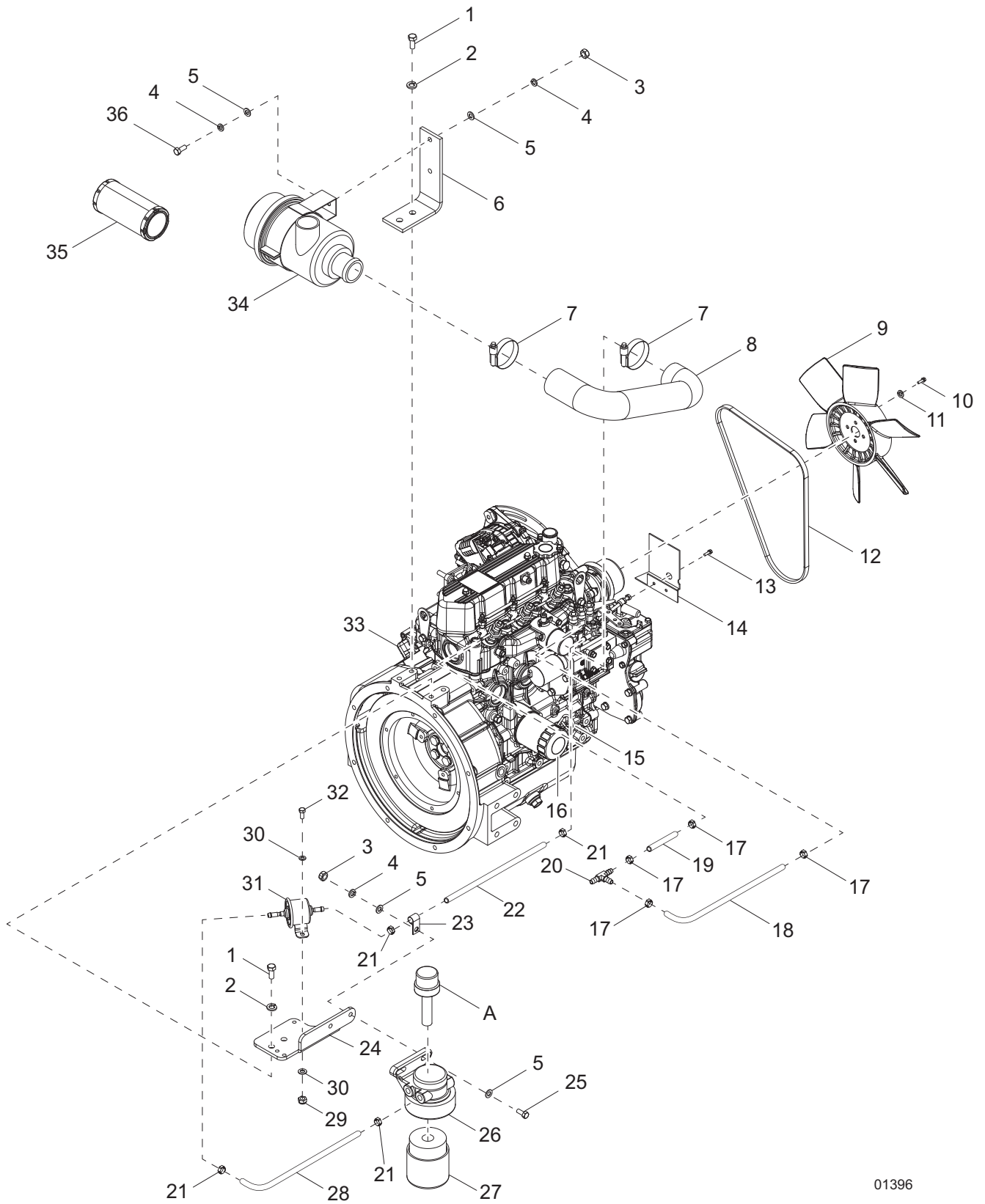

01396

ENGINE ASSEMBLY - MITSUBISHI LEFT SIDE

Item	Part No.	Qty	Description	Notes
1	60422	4	Screw, M10-1.25 x 25 std hex, G8.8	
2	60026	4	Washer, M10 split lock	
3	60285	6	Nut, .312-18 hex, G2	
4	60271	6	Washer, .312 split lock	
5	60119	8	Washer, .312 flat .875/.070	
6	16551B	1	Bracket, air cleaner - black	
7	60316	2	Clamp, hose - SAE 032 (1.56-2.50)	
8	16589	1	Hose, air cleaner	
9	16742	1	Fan, Mitsubishi	
10	63288	4	Screw, M6-1.0 x 12 pan head, G8.8	
11	60286	4	Washer, .250 split lock	
12	16692	1	V-belt, Mitsubishi	
13	13513	2	Bolt w/washer	
14	11691	1	Bracket, lower radiator hose guard	
15	11148	1	Dipstick, oil	
16	16691	1	Filter, oil - Mitsubishi	
17	60778	4	Clamp, hose - .188, crimp style	
18	14211	1.04 ft	Hose, fuel - .188 ID, 50 psi, SAE 30R7	
19	14211	.16 ft	Hose, fuel - .188 ID, 50 psi, SAE 30R7	
20	17145	1	Fitting, T - .188 x .188 x .188 barb, nylon	
21	60777	4	Clamp, hose - .312, crimp style	
22	50018	1 ft	Hose, fuel - .312 ID, 50 psi, SAE 30R7	
23	60649	1	Clamp, tubing - .750 heavy duty	
24	12838B	1	Bracket, fuel filter/pump, black	
25	60256	2	Screw, .312-18 x 1.50 std hex, G5, fully threaded	
26	17641	1	Filter, fuel	
27	17647	1	Filter, fuel, element	
28	50018	1.04 ft	Hose, fuel - .312 ID, 50 psi, 30R7	
29	60144	2	Nut, .250-20 nylock, G5	
30	60243	4	Washer, .250 flat .735/.060	
31	13278	1	Fuel pump, electric	
32	60393	2	Screw, .250-20 x 1.0 std hex, G5	
33	32885	1	Engine, Mitsubishi LE3	
34	34066	1	Filter, air, w/bracket	
35	16444	1	Element, air filter	
36	61061	2	Screw, .312-18 x .875 std hex, G5	
--	16677	1	Switch, oil pressure	

OPTIONAL FEATURES

Heated Fuel Filter:

A 13876 1 Kit, heater - fuel filter, Mitsubishi

Cold Weather Belt:

-- 10386 1 Belt, cold weather - Mitsubishi, 6kW & 8kW

Note: Engine and generator parts used in all Generac Mobile Products equipment carry the Original Equipment Manufacturer (OEM) warranty unless otherwise stated. OEM warranty parts must be purchased through an OEM dealer. Please contact Generac Mobile Products with questions.

ENGINE ASSEMBLY - MITSUBISHI RIGHT SIDE

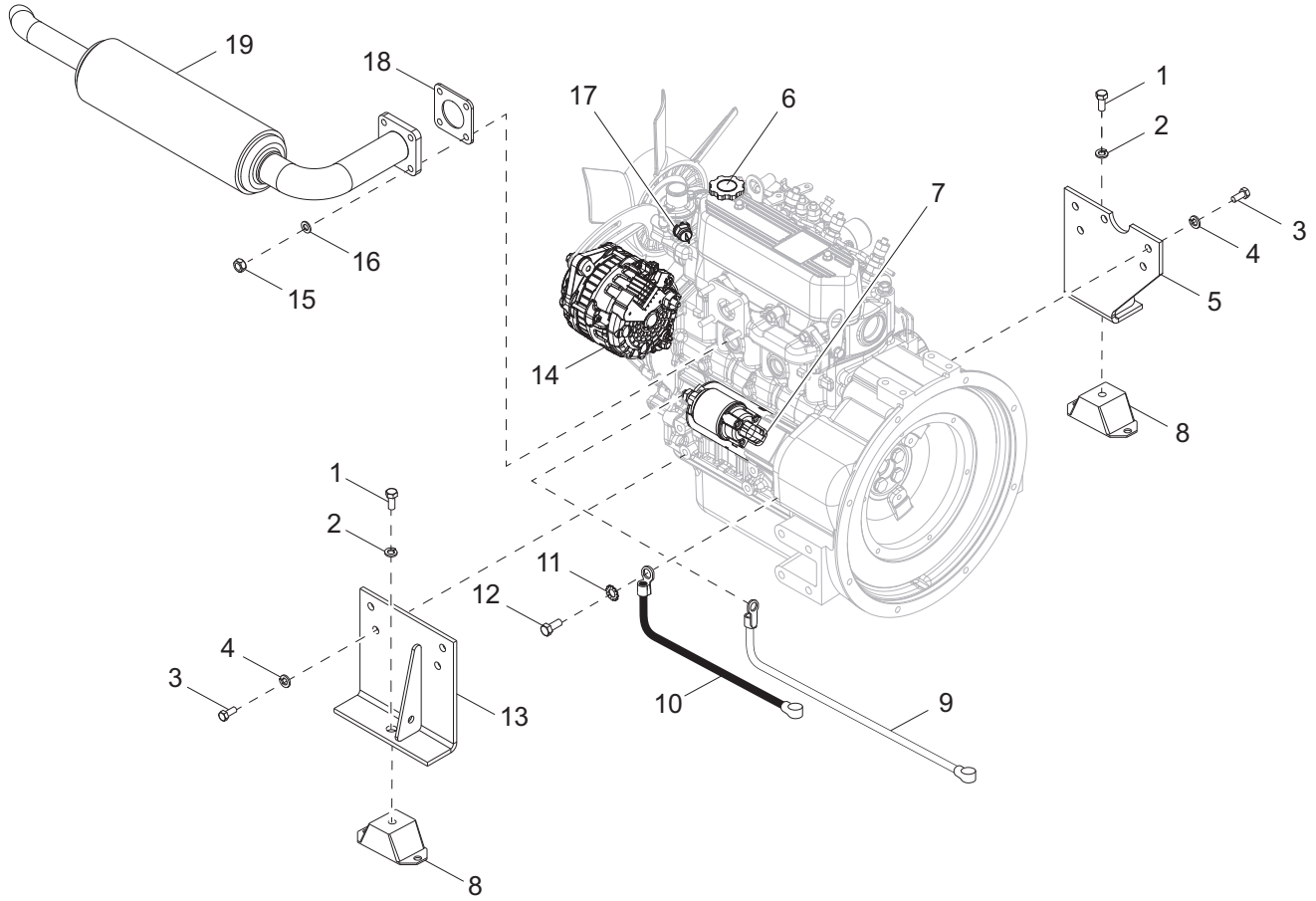

01171

ENGINE ASSEMBLY - MITSUBISHI RIGHT SIDE

Item	Part No.	Qty	Description	Notes
1	60275	2	Screw, .500-13 x 1.0 std hex, G5	
2	60702	2	Washer, .500 split lock, SS	
3	60422	8	Screw, M10-1.25 x 25 std hex, G8.8	
4	60026	8	Washer, M10 split lock	
5	16553B	1	Weldment, engine mount - right, black	
6	11147	1	Cap, oil filler	
7	16833	1	Starter	
8	15241	2	Isolator, rubber - 80-200 lbs, 2 in. wide	
9	15074	1	Cable, battery - 38 in., 4GA red, .438 lug	
10	12568	1	Cable, battery - 27 in., 4GA black, .375 lug	
11	60747	1	Washer, .375 internal star	
12	60495	1	Screw, M10-1.25 x 16 std hex, G8.8	
13	16554B	1	Weldment, engine mount - left, black	
14	16743	1	Alternator	
15	60032	4	Nut, M8-1.25 hex, G8.8	
16	60029	4	Washer, M8 split lock	
17	16678	1	Switch, temperature sensor	
18	11042	1	Gasket, muffler	
19	13710	1	Muffler, 30 degree flare	
--	10457	1	Harness, engine - Mitsubishi	

Note: Engine and generator parts used in all Generac Mobile Products equipment carry the Original Equipment Manufacturer (OEM) warranty unless otherwise stated. OEM warranty parts must be purchased through an OEM dealer. Please contact Generac Mobile Products with questions.

ENGINE ASSEMBLY - KUBOTA LEFT SIDE

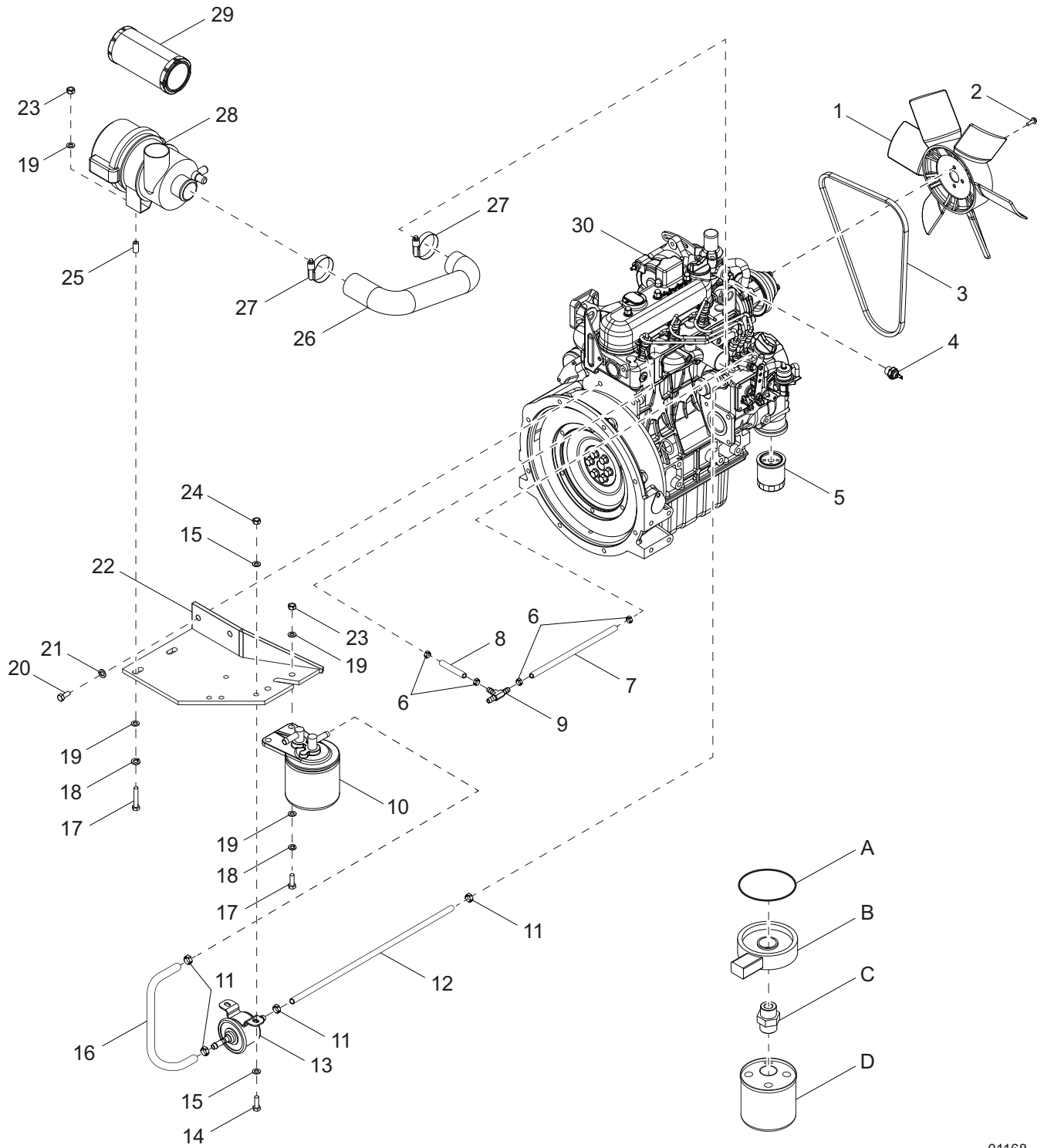

01168

ENGINE ASSEMBLY - KUBOTA LEFT SIDE

Item	Part No.	Qty	Description	Notes
1	15495	1	Fan, engine	
2	60087	4	Screw, M6-1.0 x 16 sflg hex, G8.8	
3	11628	1	Belt, V	
4	14099	1	Switch, coolant temperature	
5	10775	1	Filter, oil	
6	60778	4	Clamp, hose - .188, crimp style	
7	14211	1.3 ft	Hose, fuel - .188 ID, 50 psi, SAE 30R7	
8	14211	.167 ft	Hose, fuel - .188 ID, 50 psi, SAE 30R7	
9	17145	1	Fitting, T - .188 x .188 x .188 barb, nylon	
10	13481	1	Filter, fuel	
--	13515	1	Element, fuel filter	
11	60777	4	Clamp, hose - .312, crimp style	
12	50018	1.67 ft	Hose, fuel - .312 ID, 50 psi, SAE 30R7	
13	13278	1	Pump, fuel	
14	60393	2	Screw, .250-20 x 1.0 std hex, G5	
15	60243	4	Washer, .250 flat .735/.060	
16	50018	1 ft	Hose, fuel - .312 ID, 50 psi, SAE 30R7	
17	62001	4	Screw, .312-18 x 1.250 std hex, G5	
18	60271	4	Washer, .312 split lock	
19	60119	8	Washer, .312 flat .875/.070	
20	61082	2	Screw, M8-1.25 x 20 std hex, G8	
21	60029	2	Washer, M8 split lock	
22	13483B	1	Weldment, filter bracket	
23	60285	4	Nut, .312-18 hex, G2	
24	60144	2	Nut, .250-20 nylock, G5	
25	41235ZY	2	Spacer, .75 OD x .44 ID x 1.0 long	
26	16589	1	Hose, air cleaner	
27	60316	2	Clamp, hose - SAE 032 (1.56-2.50)	
28	34066	1	Filter, air, assembly	
29	16444	1	Element, air filter	
30	13310	1	Engine, Kubota - D1005-E3BG1-MGM-1	MLT3060KV
	13281	1	Engine, Kubota - D1105BG	MLT3080KV

OPTIONAL FEATURES

Heated Fuel Filter:

A	13834	1	Gasket, heated fuel filter
B	13682	1	Heater, fuel filter
C	10407	1	Adapter, heated fuel filter
D	13515	1	Element, heated fuel filter
--	10662	1	Harness, fuel filter heater - outside
--	13684	1	Harness, fuel filter heater - inside

Note: Engine and generator parts used in all Generac Mobile Products equipment carry the Original Equipment Manufacturer (OEM) warranty unless otherwise stated. OEM warranty parts must be purchased through an OEM dealer. Some Kubota engine parts are serial number specific. Please contact **Kubota Engine America Corp.** or the Generac Mobile Products Technical Service Department for information regarding engine parts.

ENGINE ASSEMBLY - KUBOTA RIGHT SIDE

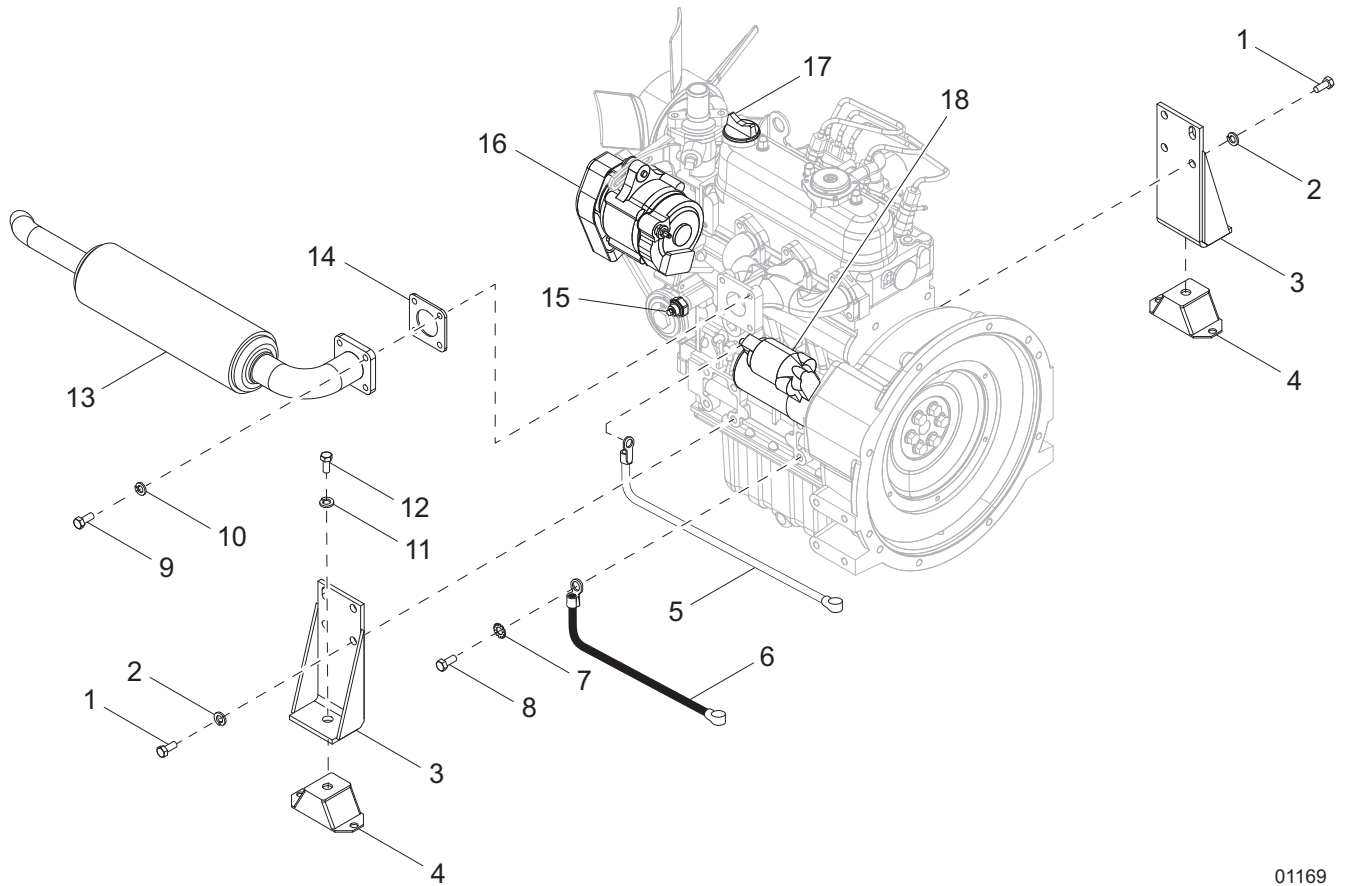

01169

ENGINE ASSEMBLY - KUBOTA RIGHT SIDE

Item	Part No.	Qty	Description	Notes
1	60422	8	Screw, M10-1.25 x 25 std hex, G8.8	
2	60026	8	Washer, M10 split lock	
3	12338B	2	Weldment, engine mount	
4	15241	2	Isolator, rubber - 80-200 lbs, 2 in. wide	
5	15074	1	Cable, battery - 38 in., 4GA red, .438 in. lug	
6	12568	1	Cable, battery - 27 in., 4GA black, .375 in. lug	
7	60747	1	Washer, .375 internal star	
8	60495	1	Screw, M10-1.25 x 16 std hex, G8.8	
9	63168	4	Screw, M8-1.25 x 30 std hex	
10	60029	4	Washer, M8 split lock	
11	60702	2	Washer, .500 split lock, SS	
12	60275	2	Screw, .500-13 x 1.0 std hex, G5	
13	13709	1	Muffler, 30 degree flare	
14	11042	1	Gasket, muffler	
15	14099	1	Switch, coolant temperature	
16	12486	1	Alternator	
17	12484	1	Cap, oil filler	
18	30582	1	Starter	MLT3060KV
	13298	1	Starter	MLT3080KV
--	10461	1	Harness, engine - Kubota	

Note: Engine and generator parts used in all Generac Mobile Products equipment carry the Original Equipment Manufacturer (OEM) warranty unless otherwise stated. OEM warranty parts must be purchased through an OEM dealer. Some Kubota engine parts are serial number specific. Please contact **Kubota Engine America Corp.** or the Generac Mobile Products Technical Service Department for information regarding engine parts.

GENERATOR ASSEMBLY

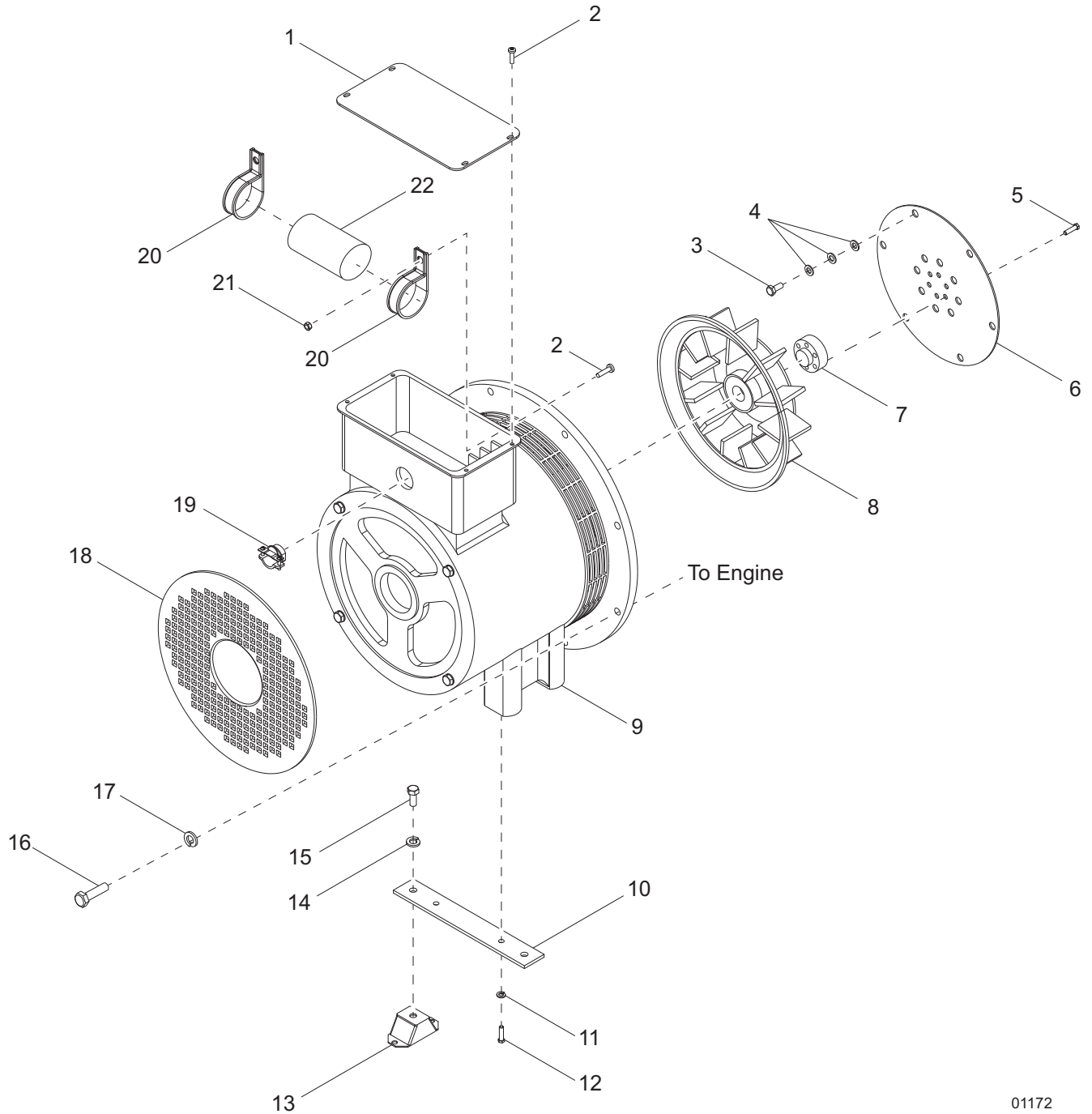

01172

GENERATOR ASSEMBLY

Item	Part No.	Qty	Description	Notes
1	12736	1	Cover, generator - 6kW	MLT3060KV/MV
	11338	1	Cover, generator - 8kW	MLT3080KV
2	60398	6	Screw, 10-32 x 5.0 pan phil, SS	
3	60168	6	Screw, .312-18 x .750 std hex, G5	MLT3060/80KV
--	60165	6	Screw, M8-1.25 x 16 std hex, G10	MLT3060MV
4	60166	18	Washer, M8 flat	MLT3060MV (qty 12 only)
5	11336	6	Screw, .375-24 x 1.75	
6	16123	1	Plate, drive - SAE 6.5	
7	11339	1	Spacer, generator drive plate	
8	12527	1	Fan, generator	
--	12329	1	Seal, pancake bearing - 6kW	Included w/item 9, MLT3060MV/KV
	11337	1	O-ring, pancake bearing - 8kW	Included w/item 9, MLT3080KV
--	12328	1	Bearing, pancake - 6kW	Included w/item 9, MLT3060MV/KV
	16134	1	Bearing, pancake - 8kW	Included w/item MLT3080KV
9	16556	1	Generator, Marathon - 6kW	MLT3060MV/KV
	10486	1	Generator, Marathon - 8kW	MLT3080KV
10	15045	1	Bracket, generator	
11	60206	2	Washer, .375 split lock	
12	60205	2	Screw, .375-16 x 1.0 std hex, G5	
13	15241	2	Isolator, rubber - 80-200 lbs, 2 in. wide	
14	60702	2	Washer, .500 split lock, SS	
15	60275	2	Screw, .50-13 x 1.0 std hex, G5	
16	60352	8	Screw, .375-16 x 1.25 std hex, G5	MLT3060/80KV
	60494	8	Screw, M10-1.25 x 30 std hex, G8.8	MLT3060MV
17	60206	8	Washer, .375 split lock	MLT3060/80KV
	60026	8	Washer, M10 split lock	MLT3060MV
18	12327	1	Cover, pancake case	
19	14219	1	Strain relief - .75 Romex w/nut	
20	16395	2	Clamp, capacitor	
21	61045	2	Nut, 10-32 sflg	
22	35132	1	Capacitor, 25 μ F 440V - 6kW	MLT3060MV/KV
	35406	1	Capacitor, 25 μ F 550V - 8kW	MLT3080KV
--	16153	1	Harness, generator - 6kW	

Note: Engine and generator parts used in all Generac Mobile Products equipment carry the Original Equipment Manufacturer (OEM) warranty unless otherwise stated. OEM warranty parts must be purchased through an OEM dealer. Please contact Generac Mobile Products with questions.

FUEL TANK AND BALLAST BOXES TO UNIT

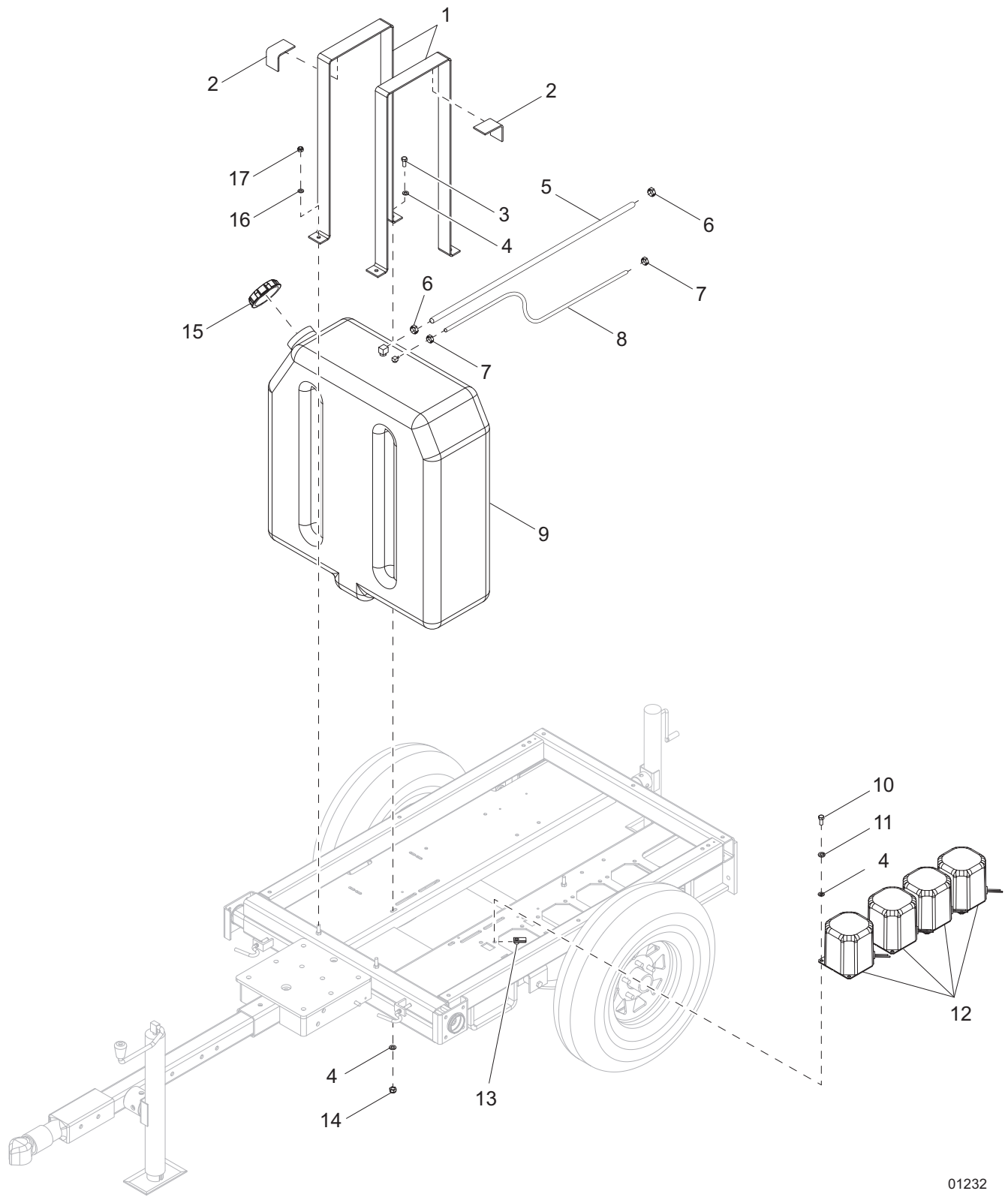

01232

FUEL TANK AND BALLAST BOXES TO UNIT

Item	Part No.	Qty	Description	Notes
1	11065B	2	Bracket, fuel tank support	
2	50197	1 ft	Weatherstripping - .06 x 1.0	Four 3 in. strips
3	60256	2	Screw, .312-18 x 1.50 std hex, G5	
4	60119	16	Washer, .312 flat .875/.070	
5	50018	2.5 ft	Hose, fuel - .312 ID, 50 psi, SAE 30R7	
6	60777	2	Clamp, hose - .312, crimp style	
7	60778	2	Clamp, hose - .188, crimp style	
8	14211	2.5 ft	Hose, fuel - .188 ID, 50 psi, SAE 30R7	
9	34668	1	Tank, fuel - 30 gallon	
10	60028	12	Screw, .312-18 x 1.0 std hex, G5	
11	60271	12	Washer, .312 split lock	
12	10656	4	Assembly, transformer - can & base - 60Hz-MH-5.5 in	
13	62086	12	Nut, .312-18 U-clip - short type	
14	60303	2	Nut, .312-18 nylock, G2	
15	12080	1	Cap, fuel tank vented - 3.5 dia green	
16	60698	2	Washer, .375 flat .875/.040, SS	
17	60358	2	Nut, .375-16 nylock, G5	

TRAILER ASSEMBLY

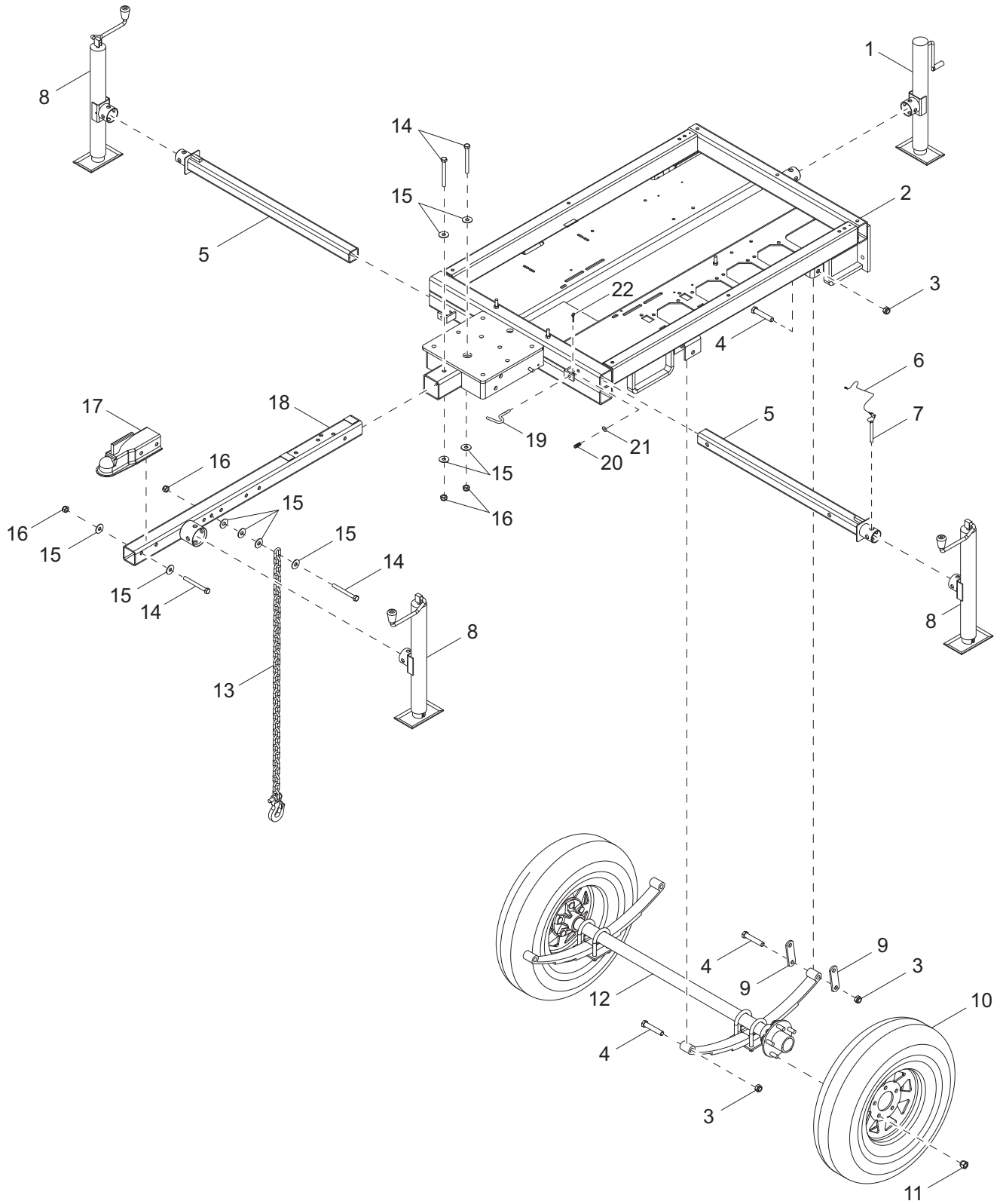

01674

TRAILER ASSEMBLY

Item	Part No.	Qty	Description	Notes
1	11978	1	Jack, side wind - 2000 lb, tube mount	
2	13819B	1	Weldment, chassis	
3	60504	8	Nut, .562-18 lock, G5	
4	60503	8	Screw, shackle, .562-18 x 3.0 std hex, G5	
5	70143Z	2	Weldment, outrigger - tube jack mount	
6	12647	4	Cable, tether - jack pin and ground rod cover	
7	23256	4	Pin, jack - 2000 lb tube mount	
8	23254	3	Jack, top wind - 2000 lb, tube mount	
9	19637	4	Plate, shackle bracket - 3.125 in	
10	15976	2	Wheel, ST175/80D13, 1360 lb - 6PR	
11	60096	10	Nut, .500-20 lug, G5	
12	Page 52	1	Assembly, axle	
13	23367	2	Chain, safety - 7800 lb rated	
14	50215	6	Screw, .500-13 x 4.0 std hex, G5	
15	60309	12	Washer, .500 flat 1.060/.090	
16	62221	6	Nut, .500-13 nylock, G5	
17	16830	1	Coupler, 2.0 ball/2.50 channel	
18	33724B	1	Weldment, removable tongue, non-shipping	
19	35272	2	Pin, plunger - .375	
20	35273	2	Spring, compression - .562 x 1.50	
21	35275	2	Washer, .375 flat .416 x .820 x .057	
22	35274	2	Pin, cotter - .078 x 1.0	
--	10307	1	Assembly, trailer light harness	
--	10266	1	Harness, right side trailer	
--	10267	1	Harness, left side trailer	
--	10262	1	Harness, main trailer	

TRAILER - JACK AND HITCH OPTIONS

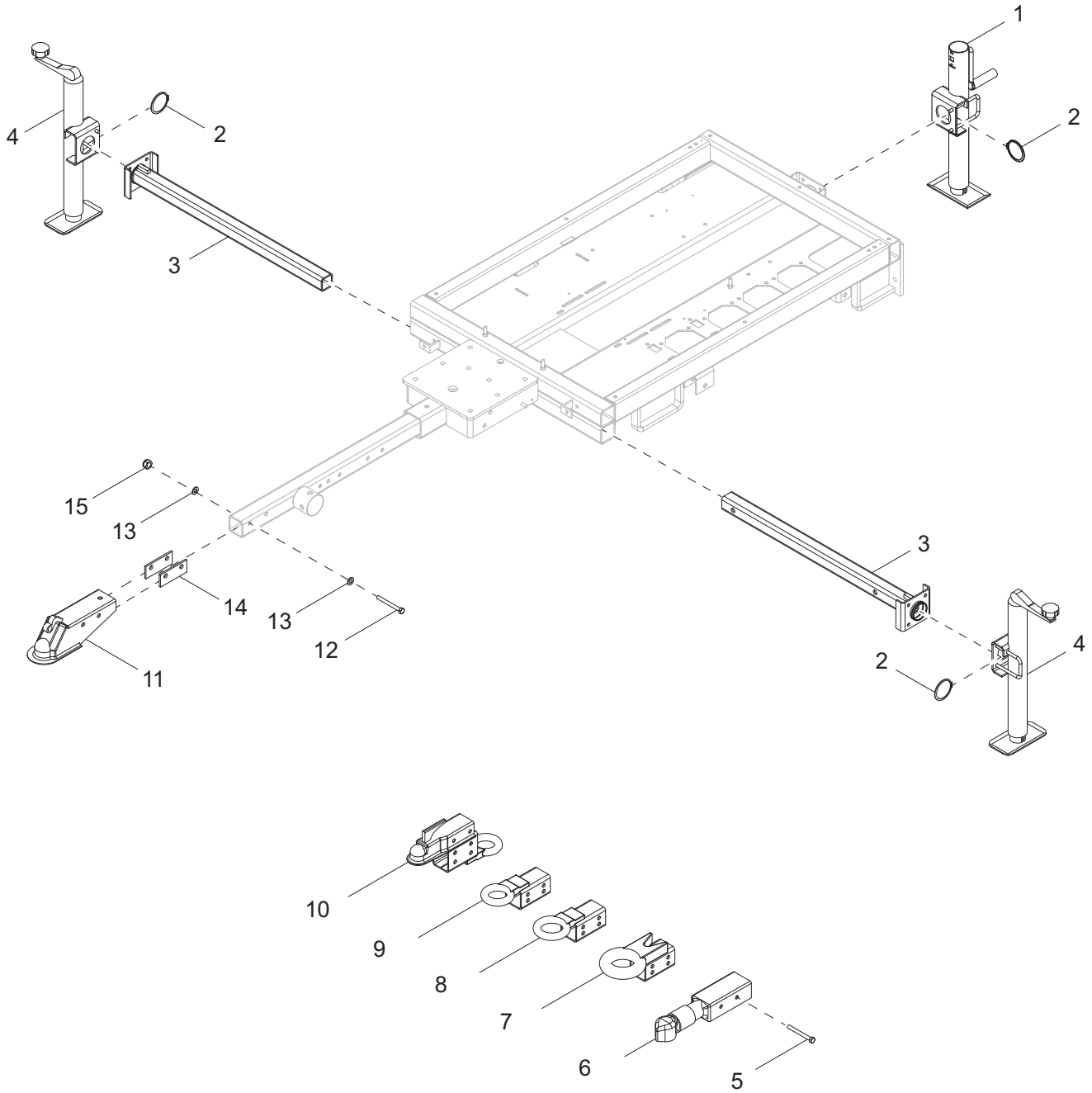

01691

TRAILER - JACK AND HITCH OPTIONS

Item	Part No.	Qty	Description	Notes
<i>Trailer Jacks and Outriggers:</i>				
1	11681	1	Jack, side wind - 2000 lb	
2	14326	3	Ring, retaining	
3	12431Z	2	Weldment, outrigger	
4	11682	2	Jack, top wind - 2000 lb	
<i>Hitches:</i>				
5	60376	2	Screw, .500-13 x 4.50 std hex, G5	
6	13003B	1	Coupler, 2.0 ball/3.0 channel	
7	11672B	1	Weldment, hitch - 3.0 x 1.625 ring/2.50 tube	
8	16835B	1	Weldment, lunette ring - 3.0 x 1.0 ring/2.50 tongue	
9	16999B	1	Weldment, lunette ring - 2.5 x 1.0 ring/2.50 tongue	
10	16741ZC	1	Weldment, combo hitch - 2.50 tongue	
11	12229	1	Coupler, 2.31 ball/3.0 channel	
12	50215	2	Screw, .500-13 x 4.0 std hex, G5	Attaches items 7 - 11
13	60309	4	Washer, .500 flat 1.060/.090	Attaches items 7 - 11
14	12155B	2	Spacer, coupler	
15	62221	2	Nut, .500-13 nylock, G5	Attaches items 6 - 11
<i>Trailer Plug Adapters:</i>				
--	65463	1	Adapter, trailer wiring - flat 4 pin to round 6 pin	
--	65464	1	Adapter, trailer wiring - flat 4 pin to round 7 pin	
--	65465	1	Adapter, trailer wiring - flat 4 pin to round 7 blade	

AXLE ASSEMBLY

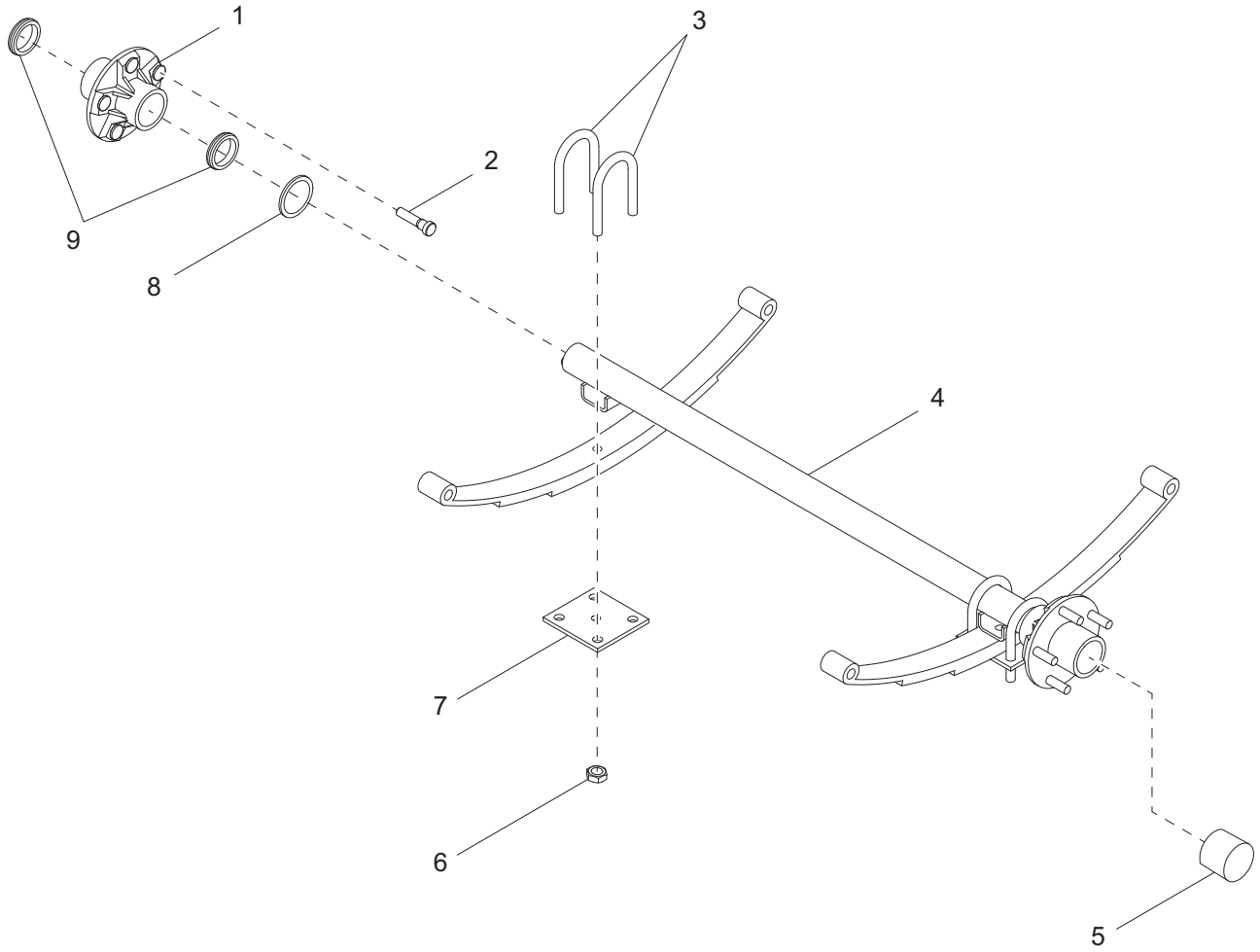

01746

AXLE ASSEMBLY

Item	Part No.	Qty	Description	Notes
1	11206	2	Axle, hub w/studs and outer races	
2	60674	10	Stud, wheel, .500-20 wheel, G8	
3	11201	4	Bolt, U	
4	11100	1	Axle, 2200 lb 40.75TC 31.00SC	
5	12460	2	Cap, wheel bearing	
6	11203	8	Nut, U-bolt, 2200 lb	
7	11202	2	Tie-plate, 2200 lb	
8	13000	2	Seal - 2200 lb	
9	11511	4	Bearing, roller	Includes bearing races

RECOMMENDED SPARE PARTS LIST (1 OF 2)

ENGINE - COMMON

Cap, radiator	19219
Element, air filter	16444
Fuel pump	13278

ENGINE - KUBOTA

Alternator	12486
Belt, fan	11628
Dipstick	12483
Element, fuel filter	13515
Element, oil filter	10775
Fan, engine	15495
Fuel shutdown solenoid	13018
Hose, radiator - lower	12350
Hose, radiator - upper	16687
Oil Cap	12484
Starter - MLT3060KV only	30582
Starter - MLT3080KV only	13298
Switch, coolant temperature	14099
Switch, oil pressure	15375

ENGINE - MITSUBISHI

Alternator	16743
Belt, fan	11692
Dipstick	11148
Element, fuel filter	17647
Element, oil filter	16691
Fan, engine	16472
Fuel shutdown solenoid	16683
Hose, radiator - lower	16688
Hose, radiator - upper	32383
Oil cap	11147
Starter	16833
Switch, coolant temperature	16678
Switch, oil pressure	16677
Thermostat	16475

ELECTRICAL

Assembly, light fixture - hard wired	13311
Assembly, light fixture - quick disconnect, cord clip	13601
Breaker, main - MLT3060KV/MV only	65963
Breaker, main - MLT3080KV only	65864
Breaker, lights	14249
Bulb	11391
Capacitor	65959
Capacitor, generator - MLT3060KV/MV only	35132
Capacitor, generator - MLT3080KV only	10242
Coil cord	33397
Contactora - electric winch	11293

RECOMMENDED SPARE PARTS LIST (2 OF 2)

GFI.....	14130
Hour meter.....	15085
Key	15309
Key switch	15195
LED board w/wires	17647
Relay, electric winch	65049
Sensor, proximity	65511
Transformer (ballast)	10930
Wago connector - 2 position	66100
Wago connector - 3 position	66101
Wago connector - 5 position	66102

MAINTENANCE KITS

Kubota 250 hour service kit	SK151
Kubota 2000 hour service kit	SK152
Mitsubishi 250 hour service kit	SK170
Mitsubishi 2000 hour service kit	SK171

MAST

Cable, 116 in.....	34132
Cable, 67.88 in	34130
Cable, 69.25 in	34128
Cable, 69.75 in	34129
Handle, winch	15623
Winch, manual - no handle.....	16600

TRAILER

Cable, tether - jack pin and ground rod cover	12647
Jack, side wind (rear)	11978
Jack, top wind (outrigger)	23254
Pin, jack - 2000 lb tube mount	23256

This Page Intentionally Left Blank

NOTES

